

Technical Note

Title: How to Configure the WebPort to Communicate with DH+ devices

Date: 6/20/08
 Product(s): All WebPort products
 Product Revision: 5.4s1 and later
 Information: **1756-DHRIO module required!**
 Document # TN062008-01

Section 1 Introduction

The WebPort can be configured to access legacy PLC processors on a DH+ network via the 1756-DHRIO module. This type of communication is allowed because the WebPort supports legacy DF1 and Rockwell's Ethernet/IP protocol. The WebPort allows the data from the network to be monitored or displayed on internal web pages that can be accessed by any user on the LAN. Remote access to the PLC over DH+ is also possible if the WebPort has an Ethernet broadband connection or a modem installed. The example shown in figure 1 demonstrates how the WebPort can be connected to access a DH+ network.

Figure 1

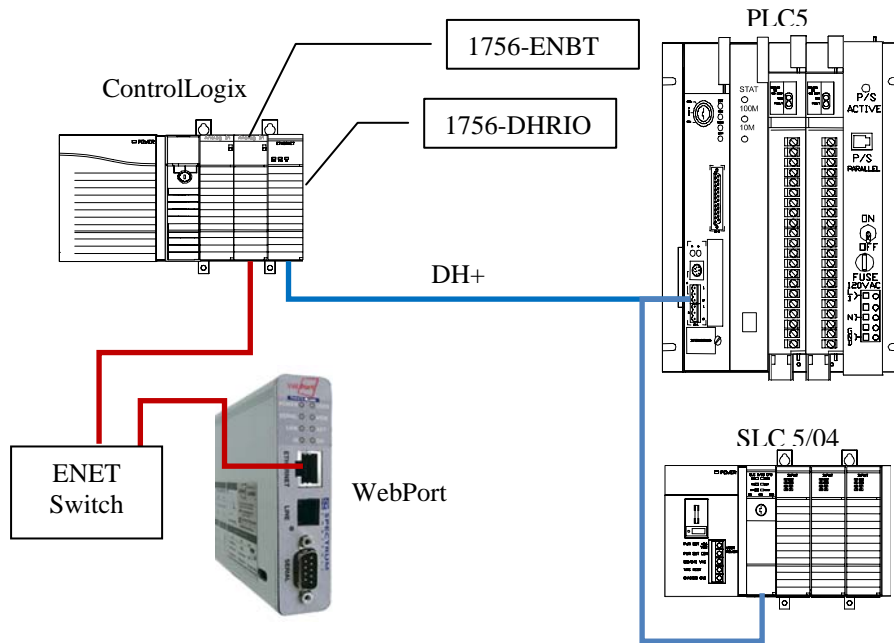

Section 2 Configuring the WebPort

The WebPort is configured using the following procedure:

- 1.) It is assumed that you have a configured DH+ network that includes a 1756 rack and 1756-DHRIO module as shown in figure 1.
- 2.) The WebPort must be installed as shown in figure 1.

Note: *The WebPort must reside in the same IP subnet as the PLC.*

- 3.) The DF1 IO server must be configured to allow communication between the WebPort and the legacy PLCs on the DH+ network. This is accomplished by entering a path in the IO server topic. The following syntax is used to define the path:

[DeviceType] - [ENBT IP address], port, link address

The device type indicates the destination PLC on the DH+ network. The device type is equal to "PLC5" or "SLC500".

Table 1 shows the possible options for the "port" parameter and table 2 shows the possible options for the "link address" parameter.

Table 1

Port	Description
1	Backplane
2	DF1 (Serial, serial CH 0), ControlNet, Ethernet/IP, DH+ Channel A
3	DH+ Channel B, DF1 CH1(serial CH 1)

Table 2

Link Address	Description
0 to N	Slot number of PLC or module
0-254	DF1 station address
1-99	ControlNet node address
1-77 Octal	DH+ node address

For example, the following IO server settings configure the WebPort to access a PLC 5 controller located behind a 1756-DHRIO, at DH+ node address 3.

Figure 2

IO Server: <input type="text" value="DF1"/> <input type="button" value="Edit"/> <input type="button" value="Clear"/> <input type="button" value="Init"/>		Global
DF1 IO Server & Gateway settings (WebPort is acting as a EIP to DF1 adapter and DF1 IO slave)		
COM Setup		
Baud Rate:	<input type="text" value="Disabled"/>	Default 9600
Parity:	<input type="text" value="None"/>	Default: NO
Stop Bit(s):	<input type="text" value="1"/>	Default: 1
Frame Error Detection:	<input type="text" value="BCC"/>	Default: CRC
HW Mode:	<input type="text" value="Full Duplex NO Handshaking"/>	Default: Full Duplex
Master response timeout:	<input type="text" value="1000"/> MS	20..60000, default: 1000
Rx message timeout:	<input type="text" value="3000"/> MS	1000..60000, default 3000
Tx message timeout:	<input type="text" value="3000"/> MS	1000..60000, default 3000
WebPort DF1 Address	<input type="text" value="4"/>	Device address of WebPort on DF1 link (0..254)
Destination DF1 Address	<input type="text" value="1"/>	Device address of destination on DF1 link when
Bridge EIP Connection	<input checked="" type="checkbox"/> Enabled	Forwarding of EIP open connection requests is
Topic A :	<input checked="" type="checkbox"/> Enabled	
Topic Name:	<input type="text" value="A"/>	
Destination Device Type and Address:	<input type="text" value="PLC5-10.0.0.4,1,2,3,3"/>	SLC500-Device Address (0..254)
Poll Rate	<input type="text" value="2000"/> MS	Default: 2000

The breakdown of the address in figure 2 is as follows:

- PLC5 = Destination PLC
- 10.0.0.4 = IP address of the 1756-ENBT
- 1 = 1756 backplane
- 2 = Slot number of 1756-DHRIO module
- 3 = CH B on DHRIO module
- 3 = DH+ node address of PLC 5

- 4.) Create PLC 5 tags using the “tag setup” screen in the WebPort configuration area. See figure 3 below.

Identification			
Tag Name:	<input type="text" value="PLC5Analog"/>	Page:	<input type="text" value="System"/>
Tag Description:	<input type="text"/>		
I/O Server Setup			
Server Name:	<input type="text" value="DF1"/>	Topic Name:	<input type="text" value="a"/>
Address:	<input type="text" value="N7:0"/>	Type:	<input type="text" value="Analog"/> <input type="checkbox"/> Force Read Only
WebPort value = IO Server Value * 1	<input type="text" value="0"/>		