

Owner's Guide 0300198-03 Rev. B

# COMPACT™ I/O UNIVERSAL ANALOG INPUT MODULE

Catalog Number: 1769sc-IF8u





## Important Notes

1. Please read all the information in this owner's guide before installing the product.
2. The information in this owner's guide applies to hardware Series A and firmware version 1.0 or later.
3. This guide assumes that the reader has a full working knowledge of the relevant processor.

### Notice

The products and services described in this owner's guide are useful in a wide variety of applications. Therefore, the user and others responsible for applying the products and services described herein are responsible for determining their acceptability for each application. While efforts have been made to provide accurate information within this owner's guide, Spectrum Controls assumes no responsibility for the accuracy, completeness, or usefulness of the information herein.

Under no circumstances will Spectrum Controls be responsible or liable for any damages or losses, including indirect or consequential damages or losses, arising out of either the use of any information within this owner's guide or the use of any product or service referenced herein.

No patent liability is assumed by Spectrum Controls with respect to the use of any of the information, products, circuits, programming, or services referenced herein.

The information in this owner's guide is subject to change without notice.

### Limited Warranty

Spectrum Controls warrants that its products are free from defects in material and workmanship under normal use and service, as described in Spectrum Controls literature covering this product, for a period of 1 year. The obligations of Spectrum Controls under this warranty are limited to replacing or repairing, at its option, at its factory or facility, any product which shall, in the applicable period after shipment, be returned to the Spectrum Controls facility, transportation charges prepaid, and which after examination is determined, to the satisfaction of Spectrum Controls, to be thus defective.

This warranty shall not apply to any such equipment which shall have been repaired or altered except by Spectrum Controls or which shall have been subject to misuse, neglect, or accident. In no case shall the liability of Spectrum Controls exceed the purchase price. The aforementioned provisions do not extend the original warranty period of any product which has either been repaired or replaced by Spectrum Controls.



# Table of Contents

|                  |    |   |    |
|------------------|----|---|----|
| Preface          | ix | Who Should Use This Manual .....                | ix |
|                  |    | How to Use This Manual .....                    | ix |
|                  |    | Related Documentation .....                     | ix |
|                  |    | Conventions Used in This Manual .....           | x  |
| Chapter 1        |    |   |    |
| Module Overview  |    |   |    |
| 1                |    | General Description .....                       | 1  |
|                  |    | Input Types and Ranges .....                    | 1  |
|                  |    | Data Formats .....                              | 2  |
|                  |    | Filter Frequencies .....                        | 2  |
|                  |    | Hardware Features .....                         | 3  |
|                  |    | System Overview .....                           | 4  |
|                  |    | Module Operation .....                          | 5  |
|                  |    | Module Field Calibration .....                  | 7  |
| Chapter 2        |    |   |    |
| Quick Start      |    |   |    |
| for Experienced  |    |   |    |
| Users            | 9  | Before You Begin .....                          | 9  |
|                  |    | Required Tools and Equipment .....              | 9  |
|                  |    | What You Need To Do .....                       | 9  |
| Chapter 3        |    |   |    |
| Installation and |    |   |    |
| Wiring           | 17 | Compliance to European Union Directives .....   | 17 |
|                  |    | Power Requirements .....                        | 18 |
|                  |    | General Considerations .....                    | 18 |
|                  |    | System Assembly .....                           | 20 |
|                  |    | Mounting .....                                  | 22 |
|                  |    | Replacing a Single Module within a System ..... | 24 |
|                  |    | Field Wiring Connections                        |    |
|                  |    | System Wiring Guidelines .....                  | 25 |
|                  |    | Cold Junction Compensation .....                | 30 |

|                      |    |   |
|----------------------|----|---|
| Chapter 4            |    |   |
| Module Data, Status, |    |   |
| and Channel          |    |   |
| Configuration        | 33 |   |
|                      |    | Module Memory Map ..... 33                          |
|                      |    | Accessing Input Image File Data ..... 34            |
|                      |    | Input Data File ..... 34                            |
|                      |    | Module Configuration ..... 36                       |
|                      |    | Determining Effective Resolution and Range ..... 50 |
|                      |    | Determining Module Update Time ..... 52             |
| <br>                 |    |   |
| Chapter 5            |    |   |
| Diagnostics and      |    |   |
| Troubleshooting      |    |   |
| 57                   |    | Safety Considerations ..... 57                      |
|                      |    | Module Operation vs. Channel Operation ..... 58     |
|                      |    | Power-up Diagnostics ..... 58                       |
|                      |    | Channel Diagnostics ..... 59                        |
|                      |    | Non-critical vs. Critical Module Errors ..... 60    |
|                      |    | Module Error Definition Table ..... 61              |
|                      |    | Error Codes ..... 62                                |
|                      |    | Module Inhibit Function ..... 63                    |
| <br>                 |    |   |
| Appendix A           |    |   |
| 1769sc-IF8U          |    |   |
| Specifications       | 65 |   |
|                      |    | Electrical Specifications                           |
|                      |    | 1769sc-IF8U ..... 65                                |
|                      |    | Environmental Conditions ..... 68                   |
|                      |    | Regulatory  |
|                      |    | Compliance ..... 68                                 |
| <br>                 |    |   |
| Appendix B           |    |   |
| Two's Complement     |    |   |
| Binary               |    |   |
| Numbers              | 69 |   |
|                      |    | Positive Decimal                                    |
|                      |    | Values ..... 69                                     |
|                      |    | Negative Decimal Values ..... 70                    |
| <br>                 |    |   |
| Appendix C           |    |   |
| Thermocouple         |    |   |
| Descriptions         | 73 |   |
|                      |    | International Temperature Scale of 1990 ..... 73    |
|                      |    | Type B Thermocouples ..... 73                       |
|                      |    | Type E Thermocouples ..... 75                       |
|                      |    | Type J Thermocouples ..... 77                       |
|                      |    | Type K Thermocouples ..... 78                       |
|                      |    | Type N Thermocouples ..... 80                       |
|                      |    | Type R Thermocouples ..... 82                       |
|                      |    | Type S Thermocouples ..... 83                       |
|                      |    | Type T Thermocouples ..... 86                       |
|                      |    | References ..... 88                                 |

Appendix D  
Using  
Thermocouple  
Junctions 95

|  |    |
|--|----|
| Using a Grounded Junction Thermocouple .....               | 95 |
| Using an Ungrounded (Isolated) Junction Thermocouple ..... | 97 |
| Using an Exposed Junction Thermocouple .....               | 97 |

Appendix E  
Module  
Configuration Using  
MicroLogix 1500  
and RSLogix 500  
101

|  |     |
|--|-----|
| Module Addressing .....  | 101 |
| Configuring the 1769sc-IF8U<br>in a MicroLogix 1500 System ..... | 103 |

Appendix F  
Configuring Your  
1769sc-IF8U Module  
with the Generic  
Profile for  
CompactLogix  
Controllers in  
RSLogix 5000 107

|  |     |
|--|-----|
| Configuring I/O Modules .....                    | 111 |
| Configuring a 1769sc-IF8U Universal Module ..... | 112 |
| Declaration of Conformity .....                  | 115 |





# Preface

Read this preface to familiarize yourself with the rest of the manual. This preface covers the following topics:

- who should use this manual
- how to use this manual
- related publications
- conventions used in this manual
- Rockwell Automation support

## Who Should Use This Manual

Use this manual if you are responsible for designing, installing, programming, or troubleshooting control systems that use Allen-Bradley Compact™ I/O and/or compatible controllers, such as MicroLogix 1500 or CompactLogix.

## How to Use This Manual

As much as possible, we organized this manual to explain, in a task-by-task manner, how to install, configure, program, operate and troubleshoot a control system using the 1769sc-IF8u.

## Related Documentation

The table below provides a listing of publications that contain important information about MicroLogix 1500 systems.

| Document Title  | Document Number  |
|---|------------------|
| MicroLogix™ 1500 User Manual  | 1764-UM001A-US-P |
| 1769 Compact Discrete Input/Output Modules Product Data               | 1769-2.1         |
| MicroLogix™ 1500 System Overview                                      | 1764-SO001B-EN-P |
| Compact™ I/O System Overview  | 1769-SO001A-EN-P |
| CompactLogix User Manual  | 1769-UM007B-EN-P |
| Allen-Bradley Programmable Controller Grounding and Wiring Guidelines | 1770-4.1         |

If you would like a manual, you can:

- download a free electronic version from the internet at [www.theautomationbookstore.com](http://www.theautomationbookstore.com)
- purchase a printed manual by:
  - contacting your local distributor or Rockwell Automation representative
  - visiting **[www.theautomationbookstore.com](http://www.theautomationbookstore.com)** and placing your order

- calling 1.800.963.9548 (USA/Canada) or 001.330.725.1574 (Outside USA/Canada)

## Conventions Used in This Manual

The following conventions are used throughout this manual:

- Bulleted lists (like this one) provide information not procedural steps.
- Numbered lists provide sequential steps or hierarchical information.
- *Italic* type is used for emphasis.
- Text in this font indicates words or phrases you should type.

# Chapter 1

## Module Overview

This chapter describes the 1769-IF8u Universal Input Module and explains how the module reads current, voltage, RTD, Resistance and thermocouple/millivolt analog input data. Included is information about:

- the module's hardware and diagnostic features
- an overview of the system and module operation
- compatibility

### General Description

The universal input module supports current, voltage, RTD, resistance, thermocouple and millivolt type inputs. The module digitally converts and stores analog data from any combination mentioned above. Each input channel is individually configured via software for a specific input device, data format and filter frequency, and provides open-circuit, over-range and under-range detection and indication.

**Note:** There are 8 on-board jumpers to configure between voltage and current modes. In current modes the module measures the input current across a low-drift precision resistor, measures the voltage, and converts to a current reading. For any input other than direct current measurements, the jumpers must be configured for voltage mode..

### Input Types and Ranges

The tables below list the input types and their associated ranges.

| Input Type | Ohms                  |
|------------|-----------------------|
| Resistance | 0-150, 0-1000, 0-3000 |

| RTD Type        | Temperature Range (*C) |
|-----------------|------------------------|
| Copper 426      | -100 to 260            |
| Nickel 618      | -100 to 260            |
| Nickel 672      | -80 to 260             |
| Nickel-Iron 518 | -200 to 200            |
| Platinum 385    | -200 to 850            |
| Platinum 3916   | -200 to 630            |

| Thermocouple Type | Temperature Range |
|-------------------|-------------------|
| Type B            | 300 to 1820C      |
| Type C            | 0 to 2315C        |
| Type E            | -270 to 1000C     |
| Type J            | -210 to 1200C     |
| Type K            | -270 to 1370C     |
| Type N            | 0 to 1300C        |
| Type R            | 0 to 1768C        |
| Type S            | 0 to 1768C        |
| Type T            | -270 to 400C      |

| Voltage Types |
|---------------|
| ± 50 mV       |
| ± 100 mV      |
| ± 10 V        |
| 0 to 10 V     |
| 0 to 5 V      |
| 1 to 5 V      |

| Current Input Range |
|---------------------|
| 0 to 20mA           |
| 4mA to 20mA         |

## Data Formats

The data can be configured on board each module as:

- engineering units x 1
- engineering units x 10
- scaled-for-PID
- percent of full-scale
- raw/proportional data

## Filter Frequencies

The module uses a digital filter that provides high frequency noise rejection for the input signals. The filter is programmable, allowing you to select from six different filter frequencies for each channel:

- 10 Hz
- 50 Hz
- 60 Hz
- 250 Hz
- 500 Hz
- 1000 Hz

## Hardware Features

The module contains a removable terminal block. Channels are wired as differential inputs with the exception of RTD and resistance type inputs. One cold junction compensation (CJC) sensor can be added to the terminal block to enable accurate readings when using thermocouple input types. The CJC sensor compensates for offset voltages introduced into the input signal as a result of the cold-junction where the thermocouple wires are connected to the module.

Module configuration is done via the controller's programming software and hardware jumper settings. In addition, some controllers support configuration via the user program. In either case, the module configuration is stored in the memory of the controller. Refer to your controller's user manual for more information. The illustration below shows the module's hardware features.

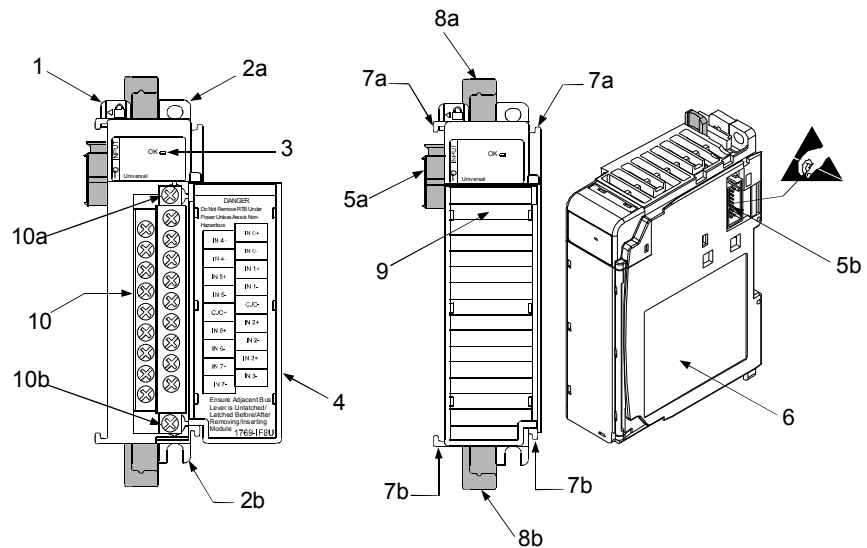

| Item | Description   |
|------|---|
| 1    | bus lever   |
| 2a   | upper panel mounting tab                                |
| 2b   | lower panel mounting tab                                |
| 3    | module status LED                                       |
| 4    | module door with terminal identification label          |
| 5a   | movable bus connector (bus interface) with female pins  |
| 5b   | stationary bus connector (bus interface) with male pins |
| 6    | nameplate label   |
| 7a   | upper tongue-and-groove slots                           |
| 7b   | lower tongue-and-groove slots                           |
| 8a   | upper DIN rail latch                                    |

|     |   |
|-----|---|
| 8b  | lower DIN rail latch                                  |
| 9   | write-on label for user identification tags           |
| 10  | removable terminal block (RTB) with finger-safe cover |
| 10a | RTB upper retaining screw                             |
| 10b | RTB lower retaining screw                             |
| 11  | CJC sensor  |

### General Diagnostic Features

The module contains a diagnostic LED that helps you identify the source of problems that may occur during power-up or during normal channel operation. The LED indicates both status and power. Power-up and channel diagnostics are explained in Chapter 5, *Diagnostics and Troubleshooting*.

## System Overview

The modules communicate to the controller through the bus interface. The modules also receive 5 and 24V dc power through the bus interface.

### System Operation

At power-up, the module performs a check of its internal circuits, memory, and basic functions. During this time, the module status LED remains off. If no faults are found during power-up diagnostics, the module status LED is turned on.

After power-up checks are complete, the module waits for valid channel configuration data. If an invalid configuration is detected, the module generates a configuration error. Once a channel is properly configured and enabled, it continuously converts the input data to a value within the range selected for that channel.

Each time a channel is read by the input module, that data value is tested by the module for an over-range, under-range, open-circuit, or “input data not valid” condition. If such a condition is detected, a unique bit is set in the channel status word. The channel status word is described in the Input Data File in chapter 4.

Using the module image table, the controller reads the two’s complement binary converted input data from the module. This typically occurs at the end of the program scan or when commanded by the control program. If the controller and the module determine that the data transfer has been made without error, the data is used in the control program.

## Module Operation

When the module receives the input from an analog device, the module's circuitry multiplexes the input into an A/D converter. The converter reads the signal and converts it as required for the type of input. If thermocouples are being utilized, the module continuously samples the CJC sensor and compensates for temperature changes at the terminal block cold junction, between the thermocouple wire and the input channel. See the block diagram below.

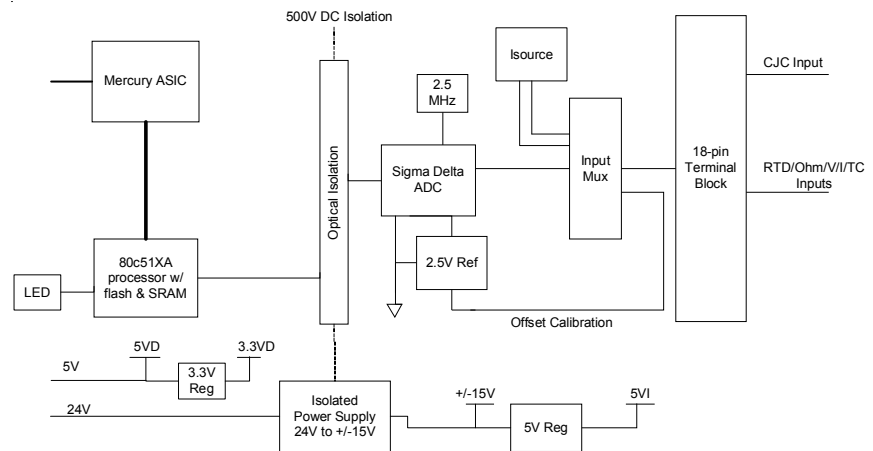

The module is designed to support up to 4 channels of RTD or resistance and up to 8 channels of voltage, current, or thermocouple, but not concurrently. For every channel of RTD or resistance the module consumes 2 possible channels of voltage, current or thermocouple inputs. This is due to terminal block limitations in a single board module. There are five possible channel configuration combinations under this design architecture. See table below.

### Configuration Choices for the 1769sc-IF8u

- 8 channels Voltage/Current/Thermocouple + 0 channels RTD/Resistance
- 6 channels Voltage/Current/Thermocouple + 1 channels RTD/Resistance
- 4 channels Voltage/Current/Thermocouple + 2 channels RTD/Resistance
- 2 channels Voltage/Current/Thermocouple + 3 channels RTD/Resistance
- 0 channels Voltage/Current/Thermocouple + 4 channels RTD/Resistance

Thermocouple and RTD measurements are linearized using the specifications listed in the table below.

| Input Type             | Specification   |
|------------------------|---|
| 100 $\Omega$ Pt 385    | IEC-751, 1983   |
| 200 $\Omega$ Pt 385    | IEC-751, 1983   |
| 500 $\Omega$ Pt 385    | IEC-751, 1983   |
| 1000 $\Omega$ Pt 385   | IEC-751, 1983   |
| 100 $\Omega$ Pt 3916   | JIS C 1604, 1989  |
| 200 $\Omega$ Pt 3916   | IEC-751, 1983   |
| 500 $\Omega$ Pt 3916   | IEC-751, 1983   |
| 1000 $\Omega$ Pt 3916  | IEC-751, 1983   |
| 10 $\Omega$ Cu 426     | SAMA RC21-4-1966  |
| 120 $\Omega$ Ni 618    | DIN 43760 Sept. 1987  |
| 120 $\Omega$ Ni 672    | MINCO Application Aid #18, Date 5/90                                      |
| 604 $\Omega$ Ni Fe 518 | MINCO Application Aid #18, Date 5/90                                      |
| J                      | NIST ITS 90   |
| K                      | NIST ITS 90   |
| T                      | NIST ITS 90   |
| E                      | NIST ITS 90   |
| R                      | NIST ITS 90   |
| S                      | NIST ITS 90   |
| B                      | NIST ITS 90   |
| N                      | NIST ITS 90   |
| C                      | From the Annual Book of Standards, American Society for Testing Materials |

Thermocouple measurements utilize a single cold junction compensation sensor placed in the center of the terminal block. Thermocouple support includes types J, K, T, E, R, S, B, N, C with a range to 100 mV. In thermocouple mode the 1769sc-IF8u will measure thermocouple and CJC sensor voltages and convert the results to a linearized temperature reading. RTD support includes types Pt 385, Pt 3916, Ni 618, Ni 672, and Cu 426. In RTD and resistance modes the module will inject a constant current through the RTD or resistor, measure the voltage across the resistance, and convert to a linearized temperature or resistance reading. RTD and resistance input types support 2, 3, or 4-wire resistance measurements.

When configured for current or voltage type inputs, the module converts the analog values directly into digital counts.



## Module Field Calibration

The module provides autocalibration, which compensates for offset and gain drift of the A/D converter caused by a temperature change within the module. An internal, high-precision, low drift voltage and system ground reference is used for this purpose. The input module performs autocalibration when a channel is initially enabled. In addition, you can program the module to perform a calibration cycle once every 5 minutes. See *Selecting Enable/Disable Cyclic Calibration (Configuration Word 0, Bit 14)* in chapter 4 for information on configuring the module to perform periodic autocalibration.



# Chapter 2

## Quick Start for Experienced Users

### Before You Begin

This chapter can help you to get started using the 1769sc-IF8u Universal input module. We base the procedures here on the assumption that you have an understanding of Allen-Bradley controllers. You should understand electronic process control and be able to interpret the ladder logic instructions required to generate the electronic signals that control your application.

Because it is a start-up guide for experienced users, this chapter does not contain detailed explanations about the procedures listed. It does, however, reference other chapters in this book where you can get more information about applying the procedures described in each step.

If you have any questions or are unfamiliar with the terms used or concepts presented in the procedural steps, always read the referenced chapters and other recommended documentation before trying to apply the information.

### Required Tools and Equipment

Have the following tools and equipment ready:

- medium blade or cross-head screwdriver
- thermocouple or millivolt analog input device
- shielded, twisted-pair cable for wiring (Belden™ 8761 or equivalent for millivolt and current inputs, Belden™ 9501, 9533 for RTD or shielded thermocouple extension wire for thermocouple inputs)
- controller (for example, a MicroLogix™ 1500 or CompactLogix™ controller)
- programming device and software (for example, RSLogix 500™ or RSLogix 5000™)

### What You Need To Do

This chapter covers:

1. Ensuring that your power supply is adequate
2. Attaching and locking the module

3. Wiring the module
4. Configuring the module
5. Going through the startup procedure
6. Monitoring module operation

**Step 1: Ensure that your 1769 system power supply(1) has sufficient current output to support your system configuration.**

**Reference**

---

Chapter 3  
(Installation and Wiring)

The modules maximum current draw is shown below

|        |        |
|--------|--------|
| 5V dc  | 24V dc |
| 150 mA | 45 mA  |

**NOTE** The module cannot be located more than 8 modules away from the system power supply.

(1) The system power supply could be a 1769-PA2, -PB2, -PA4, -PB4, or the internal supply of the MicroLogix 1500 packaged controller.

**Step 2: Attach and lock the module.**

**Reference**

---

Chapter 3  
(Installation and Wiring)

**NOTE** The module can be panel or DIN rail mounted. Modules can be assembled before or after mounting.



**ATTENTION!** Remove power before removing or inserting this module. If you remove or insert a module with power applied, an electrical arc may occur.

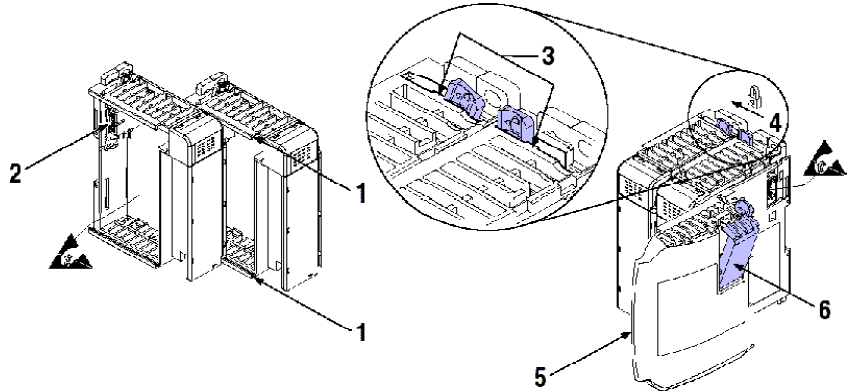

1. Check that the bus lever of the module to be installed is in the unlocked (fully right) position.
2. Use the upper and lower tongue-and-groove slots (1) to secure the modules together (or to a controller).
3. Move the module back along the tongue-and-groove slots until the bus connectors (2) line up with each other.
4. Push the bus lever back slightly to clear the positioning tab (3). Use your fingers or a small screwdriver.
5. To allow communication between the controller and module, move the bus lever fully to the left (4) until it clicks. Ensure it is locked firmly in place.
6. Attach an end cap terminator (5) to the last module in the system by using the tongue-and-groove slots as before.
7. Lock the end cap bus terminator (6).



**ATTENTION!** When attaching I/O modules, it is very important that the bus connectors are securely locked together to ensure proper electrical connection.



**IMPORTANT** A 1769-ECR or 1769-ECL right or left end cap respectively must be used to terminate the end of the 1769 communication bus.

---

**Step 3: Wire the module.**

---

**Reference**

Chapter 3  
(Installation and Wiring)

Follow the guidelines below when wiring the module.

*General*

- Power and input wiring must be in accordance with Class 1, Division 2 wiring methods, Article 501-4(b) of the National Electric Code, NFPA 70, and in accordance with the authority having jurisdiction.
- Channels are isolated from one another by  $\pm 10\text{V}$  dc maximum.
- Route field wiring away from any other wiring and keep it as far as possible from sources of electrical noise, such as motors, transformers, contactors, and ac devices. As a general rule, allow at least 15.2 cm (6 in.) of separation for every 120V of power.
- Routing field wiring in a grounded conduit can reduce electrical noise.
- If field wiring must cross ac or power cables, ensure that they cross at right angles.
- If multiple power supplies are used with analog millivolt inputs, the power supply commons must be connected.

*Terminal Block*

- Do not remove the CJC sensor from the terminal block if thermocouples are to be utilized. Removal of the sensor will reduce accuracy.  
**Note:** For improved accuracy, use a remote terminal block configuration when possible. See chapter 3 for more details.
- For millivolt and current sensors, use Belden 8761 shielded, twisted-pair wire (or equivalent) to ensure proper operation and high immunity to electrical noise.
- For RTD and resistance sensors, use Belden 9501 (2 wire), 9533 (3 wire) and 83503 ( for runs over 100 feet) or equivalent.
- For a thermocouple, use the shielded, twisted-pair thermocouple extension lead wires specified by the thermocouple manufacturer. Using the incorrect type of thermocouple extension wire or not following the correct polarity will cause invalid readings.

- To ensure optimum accuracy, limit overall cable impedance by keeping a cable as short as possible. Locate the module as close to input devices as the application permits.

### Grounding



**ATTENTION!** The possibility exists that a grounded or exposed thermocouple can become shorted to a potential greater than that of the thermocouple itself. Due to possible shock hazard, take care when wiring grounded or exposed thermocouples. See Appendix D, *Using Thermocouple Junctions*.

- This product is intended to be mounted to a well-grounded mounting surface such as a metal panel. Additional grounding connections from the module's mounting tabs or DIN rail (if used) are not required unless the mounting surface cannot be grounded.
- Keep cable shield connections to ground as short as possible.
- Ground the shield drain wire at one end only. The preferred location is as follows.
  - For grounded thermocouples or millivolt sensors, this is at the sensor end.
  - For RTD and resistance sensors, this is at the module end.
  - For insulated/ungrounded thermocouples, this is at the module end.
 Contact your sensor manufacturer for additional details.
- Refer to *Industrial Automation Wiring and Grounding Guidelines*, Allen-Bradley publication 1770-4.1, for additional information.

The terminal connections for the CJC sensor are shown below:

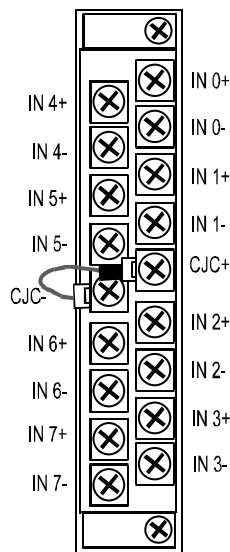

---

|                                      |                  |
|--------------------------------------|------------------|
| <b>Step 4: Configure the module.</b> | <b>Reference</b> |
|--------------------------------------|------------------|

---

Chapter 4  
(Module Data, Status, and  
Channel  
Configuration)

Circuit jumpers are located on the module to change the input path from current to voltage.

The configuration file is typically modified using the programming software compatible with your controller. It can also be modified through the control program, if supported by the controller. See Channel Configuration in chapter 4 for more information.

|  |                  |
|--|------------------|
| <b>Step 5: Go through the startup procedure.</b> | <b>Reference</b> |
|--|------------------|

---

Chapter 5  
(Diagnostics and  
Troubleshooting)

1. Apply power to the controller system.
2. Download your program, which contains the universal module configuration settings, to the controller.
3. Put the controller in Run mode. During a normal start-up, the module status LED turns on.

**NOTE** If the module status LED does not turn on, cycle power. If the condition persists, contact your local distributor or Spectrum Controls for assistance.

|  |                  |
|--|------------------|
| <b>Step 6: Monitor the module status to check if the module is operating correctly</b> | <b>Reference</b> |
|--|------------------|

---

Chapter 5 (Diagnostics and  
Troubleshooting)

Module and channel configuration errors are reported to the controller. These errors are typically reported in the controller's I/O status file. Channel status data is also reported in the module's input data table, so these bits can be used in your control program to flag a channel error.







# Chapter 3

## Installation and Wiring

This chapter tells you how to:

- determine the power requirements for the module
- avoid electrostatic damage
- install the module
- wire the module's terminal block
- wire input devices

### Compliance to European Union Directives

This product is approved for installation within the European Union and EEA regions. It has been designed and tested to meet the following directives.

#### **EMC Directive**

The 1769sc-IF8u module is tested to meet Council Directive 89/336/EEC Electromagnetic Compatibility (EMC) and the following standards, in whole or in part, documented in a technical construction file:

- EN 61000-6-4  
EMC – Generic Emission Standard, Part 2 - Industrial Environment
- EN 61000-6-2  
EMC – Generic Immunity Standard, Part 2 - Industrial Environment

This product is intended for use in an industrial environment.

#### **Low Voltage Directive**

This product is tested to meet Council Directive 2006/95/EC Low Voltage, by applying the safety requirements of EN 61131-2 Programmable Controllers, Part 2 – Equipment Requirements and Tests. For specific information required by EN61131-2, see the appropriate sections in this publication, as well as the following Allen-Bradley publications:

- *Industrial Automation, Wiring and Grounding Guidelines for Noise Immunity*, publication 1770-4.1
- *Automation Systems Catalog*, publication B113

## Power Requirements

The module receives power through the bus interface from the +5V dc/ +24V dc system power supply. The maximum current drawn by the module is shown in the table below.

| Module Current Draw | at 5V dc | at 24V dc |
|---------------------|----------|-----------|
|                     | 150 mA   | 45 mA     |

## General Considerations

Compact I/O is suitable for use in an industrial environment when installed in accordance with these instructions. Specifically, this equipment is intended for use in clean, dry environments (Pollution degree 2(1)) and to circuits not exceeding Over Voltage Category II(2) (IEC 60664-1).(3)

### Hazardous Location Considerations

This equipment is suitable for use in Class I, Division 2, Groups A, B, C, D or non-hazardous locations only. The following WARNING statement applies to use in hazardous locations.



#### WARNING!

- EXPLOSION HAZARD
- Substitution of components may impair suitability for Class I, Division 2.
- Do not replace components or disconnect equipment unless power has been switched off or the area is known to be non-hazardous.
- Do not connect or disconnect components unless power has been switched off or the area is known to be non-hazardous.
- This product must be installed in an enclosure.
- All wiring must comply with N.E.C. article 501-4(b).

(1) Pollution Degree 2 is an environment where, normally, only non-conductive pollution occurs except that occasionally a temporary conductivity caused by condensation shall be expected.

(2) Over Voltage Category II is the load level section of the electrical distribution system. At this level transient voltages are controlled and do not exceed the impulse voltage capability of the product's insulation.

(3) Pollution Degree 2 and Over Voltage Category II are International Electrotechnical Commission (IEC) designations.

---

## Prevent Electrostatic Discharge



**ATTENTION!** Electrostatic discharge can damage integrated circuits or semiconductors if you touch analog I/O module bus connector pins or the terminal block on the input module. Follow these guidelines when you handle the module:

- Touch a grounded object to discharge static potential.
  - Wear an approved wrist-strap grounding device.
  - Do not touch the bus connector or connector pins.
  - Do not touch circuit components inside the module.
  - If available, use a static-safe work station.
  - When it is not in use, keep the module in its static-shield bag.
- 

## Remove Power



**ATTENTION!** Remove power before removing or inserting this module.

When you remove or insert a module with power applied, an electrical arc may occur. An electrical arc can cause personal injury or property damage by:

- sending an erroneous signal to your system's field devices, causing unintended machine motion
- causing an explosion in a hazardous environment

Electrical arcing causes excessive wear to contacts on both the module and its mating connector and may lead to premature failure.

---

## Selecting a Location

### *Reducing Noise*

Most applications require installation in an industrial enclosure to reduce the effects of electrical interference. Analog inputs are highly susceptible to electrical noise. Electrical noise coupled to the analog inputs will reduce the performance (accuracy) of the module.

Group your modules to minimize adverse effects from radiated electrical noise and heat. Consider the following conditions when selecting a location for the analog module. Position the module:

- away from sources of electrical noise such as hard-contact switches, relays, and AC motor drives
- away from modules which generate significant radiated heat, such as the 1769-IA16. Refer to the module’s heat dissipation specification.

In addition, route shielded, twisted-pair analog input wiring away from any high voltage I/O wiring.

*Power Supply Distance*

You can install as many modules as your power supply can support. However, all 1769 I/O modules have a power supply distance rating. The maximum I/O module rating is 8, which means that a module may not be located more than 8 modules away from the system power supply.

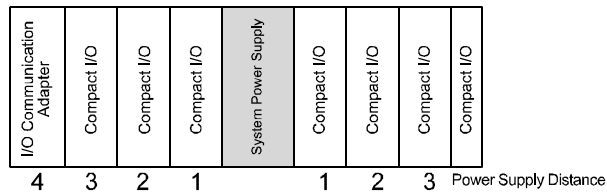
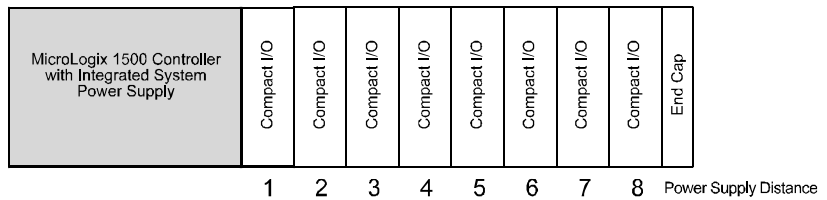

**System Assembly**

The module can be attached to the controller or an adjacent I/O module *before* or *after* mounting. For mounting instructions, see Panel Mounting Using the Dimensional Template, or DIN Rail Mounting. To work with a system that is already mounted, see Replacing a Single Module within a System.

The following procedure shows you how to assemble the Compact I/O system.

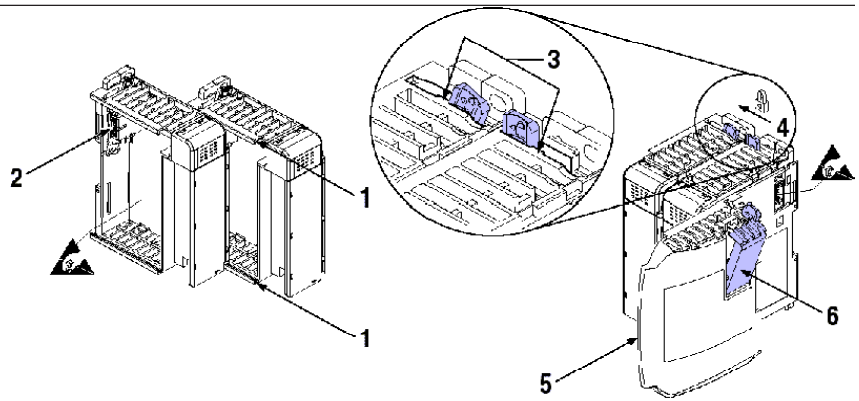

1. Disconnect power.

2. Check that the bus lever of the module to be installed is in the unlocked (fully right) position.

**NOTE:** If the module is being installed to the left of an existing module, check that the right-side adjacent module's bus lever is in the unlocked (fully right) position.

3. Use the upper and lower tongue-and-groove slots (1) to secure the modules together (or to a controller).

4. Move the module back along the tongue-and-groove slots until the bus connectors (2) line up with each other.

5. Push the bus lever back slightly to clear the positioning tab (3). Use your fingers or a small screwdriver.

6. To allow communication between the controller and module, move the bus lever fully to the left (4) until it clicks. Ensure it is locked firmly in place.



**ATTENTION!** When attaching I/O modules, it is very important that the bus connectors are securely locked together to ensure proper electrical connection.

7. Attach an end cap terminator (5) to the last module in the system by using the tongue-and-groove slots as before.

8. Lock the end cap bus terminator (6).



**IMPORTANT:** A 1769-ECR or 1769-ECL right or left end cap respectively must be used to terminate the end of the bus.

## Mounting



**ATTENTION!** During panel or DIN rail mounting of all devices, be sure that all debris (metal chips, wire strands, etc.) is kept from falling into the module. Debris that falls into the module could cause damage at power up.

### Minimum Spacing

Maintain spacing from enclosure walls, wireways, adjacent equipment, etc. Allow 50 mm (2 in.) of space on all sides for adequate ventilation, as shown below:

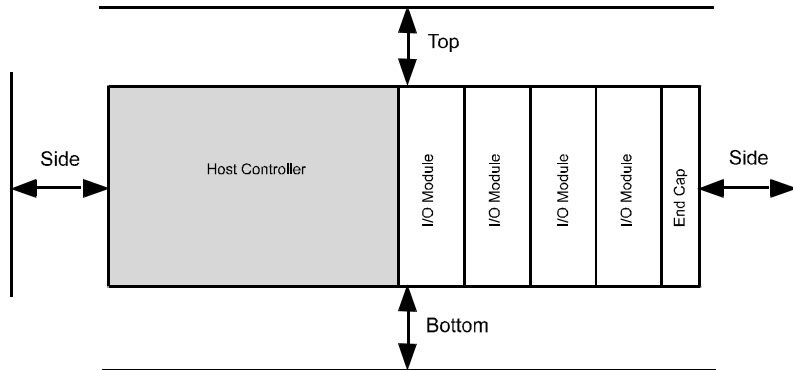

### Panel Mounting

Mount the module to a panel using two screws per module. Use M4 or #8 panhead screws. Mounting screws are required on every module.

#### Panel Mounting Using the Dimensional Template

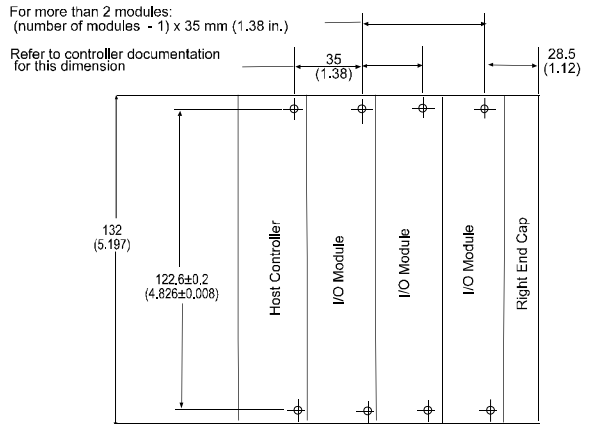

Note: All dimensions are in mm (in.).  
 Hole spacing tolerance is ±0.4 mm (0.016 in.).



---

*Panel Mounting Procedure Using Modules as a Template*

The following procedure allows you to use the assembled modules as a template for drilling holes in the panel. If you have sophisticated panel mounting equipment, you can use the dimensional template provided on the previous page. Due to module mounting hole tolerance, it is important to follow these procedures:

1. On a clean work surface, assemble no more than three modules.
2. Using the assembled modules as a template, carefully mark the center of all module-mounting holes on the panel.
3. Return the assembled modules to the clean work surface, including any previously mounted modules.
4. Drill and tap the mounting holes for the recommended M4 or #8 screw.
5. Place the modules back on the panel, and check for proper hole alignment.
6. Attach the modules to the panel using the mounting screws.

**NOTE** If mounting more modules, mount only the last one of this group and put the others aside. This reduces remounting time during drilling and tapping of the next group.

7. Repeat steps 1 to 6 for any remaining modules.

**DIN Rail Mounting**

The module can be mounted using the following DIN rails:

- 35 x 7.5 mm (EN 50 022 - 35 x 7.5), or
- 35 x 15 mm (EN 50 022 - 35 x 15).

Before mounting the module on a DIN rail, close the DIN rail latches. Press the DIN rail mounting area of the module against the DIN rail. The latches will momentarily open and lock into place.

## Replacing a Single Module within a System

The module can be replaced while the system is mounted to a panel (or DIN rail). Follow these steps in order:

1. Remove power. See important note at the beginning of this chapter.
2. On the module to be removed, remove the upper and lower mounting screws from the module (or open the DIN latches using a flat-blade or phillips-style screwdriver).
3. Move the bus lever to the right to disconnect (unlock) the bus.
4. On the right-side adjacent module, move its bus lever to the right (unlock) to disconnect it from the module to be removed.
5. Gently slide the disconnected module forward. If you feel excessive resistance, check that the module has been disconnected from the bus, and that both mounting screws have been removed (or DIN latches opened).

**NOTE:** It may be necessary to rock the module slightly from front to back to remove it, or, in a panel-mounted system, to loosen the screws of adjacent modules.

6. Before installing the replacement module, be sure that the bus lever on the module to be installed and on the right-side adjacent module or end cap are in the unlocked (fully right) position.
7. Slide the replacement module into the open slot.
8. Connect the modules together by locking (fully left) the bus levers on the replacement module and the right-side adjacent module.
9. Replace the mounting screws (or snap the module onto the DIN rail).

## Field Wiring Connections System Wiring Guidelines

Consider the following when wiring your system:

### *General*

- Power and input wiring must be in accordance with Class 1, Division 2 wiring methods, Article 501-4(b) of the National Electric Code, NFPA 70, and in accordance with the authority having jurisdiction.
- Channels are isolated from one another by  $\pm 10$  Vdc maximum.
- Route field wiring away from any other wiring and as far as possible from sources of electrical noise, such as motors, transformers, contactors, and ac devices. As a general rule, allow at least 15.2 cm (6 in.) of separation for every 120V of power.
- Routing field wiring in a grounded conduit can reduce electrical noise.
- If field wiring must cross ac or power cables, ensure that they cross at right angles.
- If multiple power supplies are used with analog millivolt inputs, the power supply commons must be connected.
- Provision shall be made to prevent the rated voltage being exceeded by the transient disturbances of more than 40%.
- The system shall be mounted in an ATEX certified enclosure with a minimum ingress protection rating of at least IP54 as defined in IEC60529 or EN60529 and used in an environment of not more than pollution degree 2.
- Earthing is accomplished through mounting of modules on rail.
- Subject devices are for operation in Ambient Temperature Range: 0 C to +60 C

### *Terminal Block*

- Do not remove the CJC sensor from the terminal block if thermocouples are to be utilized. Removal of the sensor will reduce accuracy.
- For millivolt and current sensors, use Belden 8761 shielded, twisted-pair wire (or equivalent) to ensure proper operation and high immunity to electrical noise.
- For RTD and resistance sensors, use Belden 9501 (2 wire), 9533 (3 wire) and 83503 ( for runs over 100 feet) or equivalent.
- For a thermocouple, use the shielded, twisted-pair thermocouple extension lead wires specified by the thermocouple manufacturer.

Using the incorrect type of thermocouple extension wire or not following the correct polarity will cause invalid readings.

- To ensure optimum accuracy, limit overall cable impedance by keeping a cable as short as possible. Locate the module as close to input devices as the application permits.

### *Grounding*



**ATTENTION!** The possibility exists that a grounded or exposed

**thermocouple can become shorted to a potential greater than that of the thermocouple itself. Due to possible shock hazard, take care when wiring grounded or exposed thermocouples. See Appendix D, Using Thermocouple Junctions.**

- This product is intended to be mounted to a well-grounded mounting surface such as a metal panel. Additional grounding connections from the module's mounting tabs or DIN rail (if used) are not required unless the mounting surface cannot be grounded.
- Keep cable shield connections to ground as short as possible.
- Ground the shield drain wire at one end only. The typical location is as follows.
  - For grounded thermocouples or millivolt sensors, this is at the sensor end.
  - For insulated/ungrounded thermocouples, this is at the module end. Contact your sensor manufacturer for additional details.
- If it is necessary to connect the shield drain wire at the module end, connect it to earth ground using a panel or DIN rail mounting screw.
- Refer to *Industrial Automation Wiring and Grounding Guidelines*, Allen-Bradley publication 1770-4.1, for additional information.

### *Noise Prevention*

- To limit the pickup of electrical noise, keep thermocouple and millivolt signal wires as far as possible from power and load lines.
- If noise persists for a device, try grounding the opposite end of the cable shield. (You can only ground one end at a time.)

### Terminal Door Label

A removable, write-on label is provided with the module. Remove the label from the door, mark your unique identification of each terminal with permanent ink, and slide the label back into the door. Your markings (ID tag) will be visible when the module door is closed.

### Removing and Replacing the Terminal Block

When wiring the module, you do not have to remove the terminal block. If you remove the terminal block, use the write-on label located on the side of the terminal block to identify the module location and type.



To remove the terminal block, loosen the upper and lower retaining screws. The terminal block will back away from the module as you remove the screws. Be careful not to damage the CJC sensors. When replacing the terminal block, torque the retaining screws to 0.46 Nm (4.1 in-lbs).

### Wiring the Finger-Safe Terminal Block

When wiring the terminal block, keep the finger-safe cover in place.

1. Loosen the terminal screws to be wired.
2. Route the wire under the terminal pressure plate. You can use the bare wire or a spade lug. The terminals accept a 6.35 mm (0.25 in.) spade lug.

**NOTE:** The terminal screws are non-captive. Therefore, it is possible to use a ring lug [maximum 1/4 inch o.d. with a 0.139 inch minimum i.d. (M3.5)] with the module.

3. Tighten the terminal screw making sure the pressure plate secures the wire. Recommended torque when tightening terminal screws is 0.68 Nm (6 in-lbs).

**NOTE:** If you need to remove the finger-safe cover, insert a screwdriver into one of the square, wiring holes and gently pry the cover off. If you wire the terminal block with the finger-safe cover removed, you may not be able to put it back on the terminal block because the wires will be in the way.

### Wire Size and Terminal Screw Torque

Each terminal accepts up to two wires with the following restrictions:

| Wire Type                | Wire Size                           | Terminal Screw Torque | Retaining Screw Torque |
|--------------------------|-------------------------------------|-----------------------|------------------------|
| Solid Cu-90°C (194°F)    | #14 to #22 AWG<br>(1.63 to 0.65 mm) | 0.68 Nm (6 in-lbs)    | 0.46 Nm (4.1 in-lbs)   |
| Stranded Cu-90°C (194°F) | #16 to #22 AWG<br>(1.63 to 0.65 mm) | 0.68 Nm (6 in-lbs)    | 0.46 Nm (4.1 in-lbs)   |



**ATTENTION!** Use supply wires suitable for 20°C above surrounding ambient.

### Wiring the Module



**ATTENTION!** To prevent shock hazard, care should be taken when wiring the module to analog signal sources. Before wiring any module, disconnect power from the system power supply and from any other source to the module.

After the module is properly installed, follow the wiring procedure below, using the proper thermocouple extension cable, Belden 8761 for non-thermocouple applications excluding RTDs and Belden 9533 or 83503 for RTD/Resistance type inputs.

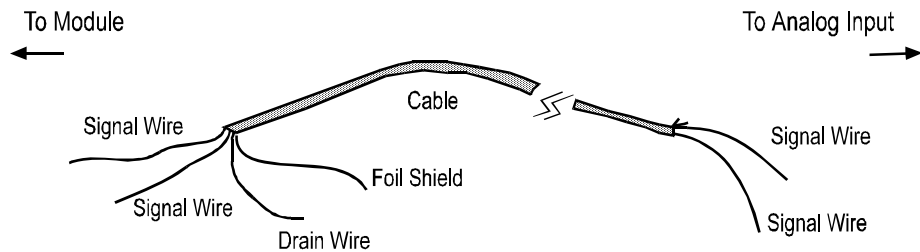

To wire your module follow these steps.

1. At each end of the cable, strip some casing to expose the individual wires.
2. Trim the signal wires to 2-inch (5 cm) lengths. Strip about 3/16 inch (5 mm) of insulation away to expose the end of the wire.



**ATTENTION!** Be careful when stripping wires. Wire fragments that fall into a module could cause damage at power up.

3. At one end of the cable, twist the drain wire and foil shield together, bend them away from the cable, and apply shrink wrap. Then earth ground at the preferred location based on the type of sensor you are using. See Grounding for more details.
4. At the other end of the cable, cut the drain wire and foil shield back to the cable and apply shrink wrap.
5. Connect the signal wires to the terminal block. Connect the other end of the cable to the analog input device.
6. Repeat steps 1 through 5 for each channel on the module.

**NOTE:** See Appendix D *Using Thermocouple Junctions* for additional information on wiring grounded, ungrounded, and exposed thermocouple types.

### Wiring Diagrams

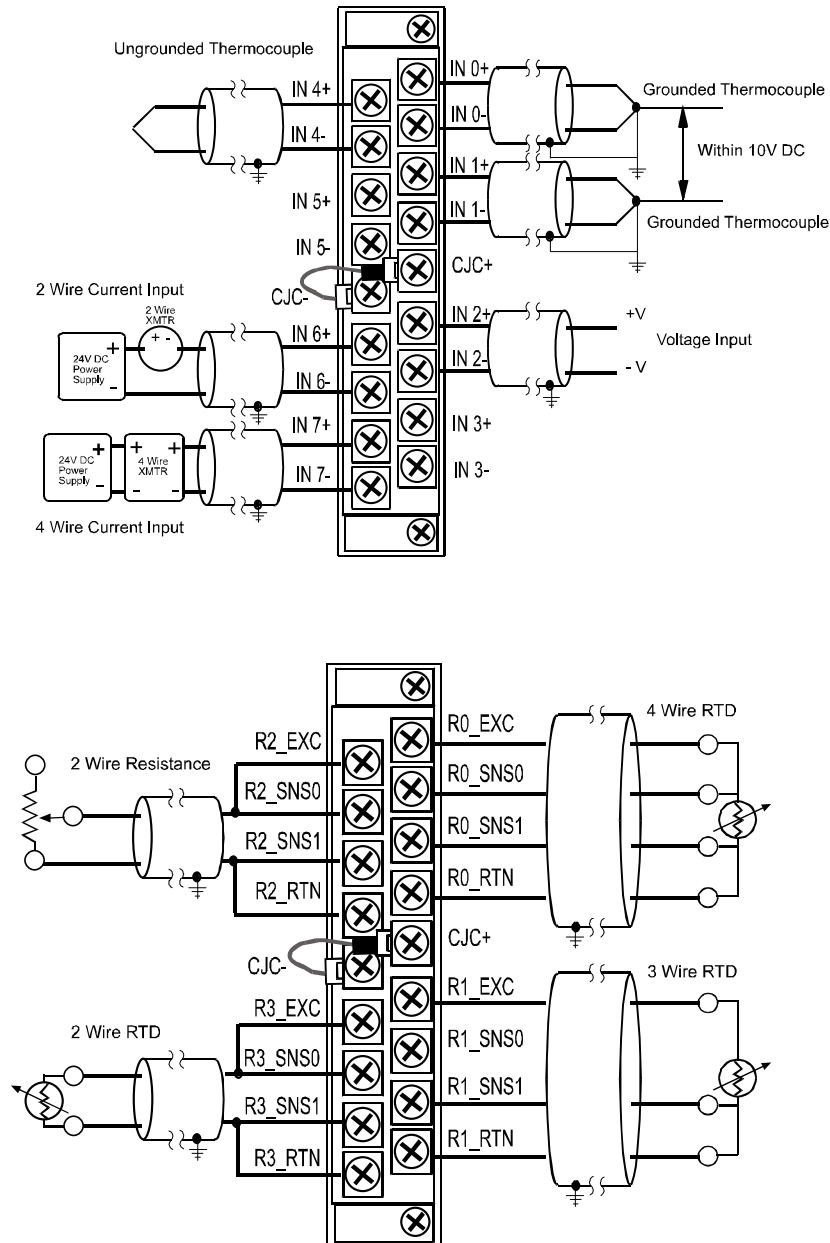

**NOTE:** When using an ungrounded thermocouple, the shield must be connected to ground at the module end.



**IMPORTANT:** When using grounded and/or exposed thermocouples

that are touching electrically conductive material, the ground potential between any two channels cannot exceed  $\pm 10V$  dc, or temperature readings will be inaccurate.

## Cold Junction Compensation

To obtain accurate readings from channels configured for thermocouple, the cold junction temperature (temperature at the module's terminal junction between the thermocouple wire and the input channel) must be compensated. One cold junction compensating thermistor has been integrated into the removable terminal block. This thermistor must remain installed to retain accuracy. If the thermistor assembly is accidentally removed, re-install it by connecting it across the CJC terminals.

**Note:** Thermocouple accuracy can differ between channels on the terminal block. Channels that are physically located further from the CJC sensor are more likely to exhibit a temperature offset. The figure below shows the CJC accuracy for each channel.

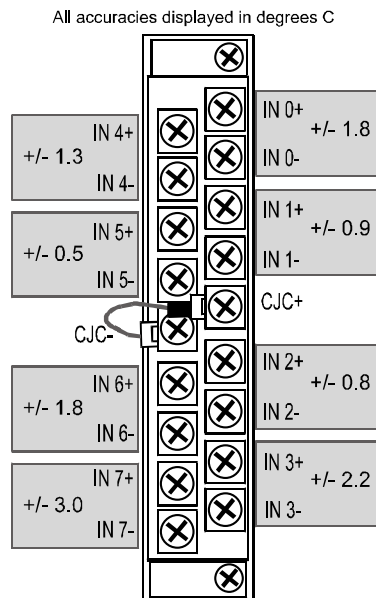

**Note:** Using a remote terminal block can improve CJC accuracy. When using remote terminal blocks, remove the CJC sensor from the module RTB and mount it on the remote terminal block. Be sure to use shielded twisted pair wire between the module and the remote



terminal block. Do not mount the remote terminal block near heat sources, as it will cause inaccurate readings.



**ATTENTION!** Do not remove or loosen the cold junction compensating

thermistor assembly located between the two CJC terminals. The thermistor assembly must be installed to ensure accurate thermocouple input readings on channels configured for thermocouple. The module will operate in the thermocouple mode, but at reduced accuracy if the CJC sensor is removed. See *Determining Open-Circuit Response (Bits 4 and 5)* in chapter 4.

---

### Calibration

The universal module is initially calibrated at the factory. The module also has an autocalibration function.

When an autocalibration cycle takes place, the module's multiplexer is set to system ground potential and an A/D reading is taken. The A/D converter then sets its internal input to the module's precision voltage source, and another reading is taken. The A/D converter uses these numbers to compensate for system offset (zero) and gain (span) errors.

Autocalibration of a channel occurs whenever a channel is enabled. You can also program your module to perform cyclic calibration cycles, every five minutes. See *Selecting Enable/Disable Cyclic Calibration (Word 0, Bit 14)* in chapter 4.

To maintain optimal system accuracy, periodically perform an autocalibration cycle.



**IMPORTANT:** The module does not convert input data while the

calibration cycle is in progress following a change in configuration. Module scan times are increased by up to 112 ms during cyclic autocalibration.

---



## Chapter 4 Module Data, Status, and Channel Configuration

After installing the 1769-IF8u universal input module, you must configure it for operation, usually using the programming software compatible with the controller (for example, RSLogix 500 or RSLogix 5000). Once configuration is complete and reflected in the ladder logic, you need to operate the module and verify its configuration.

This chapter contains information on the following:

- module memory map
- accessing input image file data
- configuring channels
- determining effective resolution and range
- determining module update time

### Module Memory Map

The module uses eleven input words for data and status bits (input image), and eighteen configuration words.

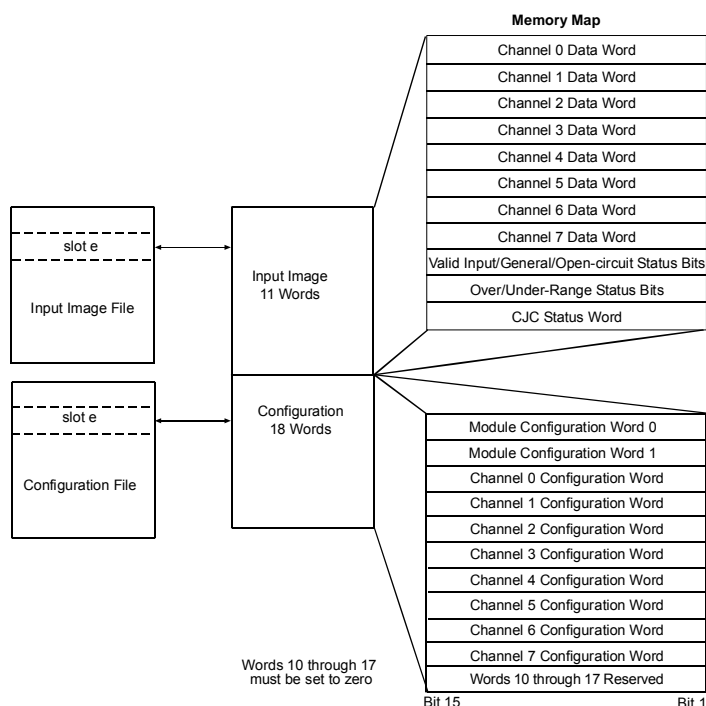

**NOTE:** Not all controllers support program access to the configuration file. Refer to your controller's user manual.

## Accessing Input Image File Data

The input image file represents data words and status words. Input words 0 through 7 hold the input data that represents the value of the analog inputs for channels 0 through 7. These data words are valid only when the channel is enabled and there are no errors. Input words 8, 9 and 10 hold the status bits. To receive valid status information, the channel must be enabled.

You can access the information in the input image file using the programming software configuration screen. For information on configuring the module in a MicroLogix 1500 system using RSLogix 500, see Appendix E; for CompactLogix using RSLogix 5000, see Appendix F.

## Input Data File

The input data table allows you to access module read data for use in the control program, via word and bit access. The data table structure is shown in the table below.

**Table 4.1 Input Data Table**

| Word/Bit <sup>(1)</sup> | 15                          | 14  | 13  | 12  | 11   | 10  | 9   | 8   | 7  | 6  | 5  | 4  | 3  | 2  | 1  | 0  |
|-------------------------|-----------------------------|-----|-----|-----|--|-----|-----|-----|----|----|----|----|----|----|----|----|
| 0                       | Analog Input Data Channel 0 |     |     |     |  |     |     |     |    |    |    |    |    |    |    |    |
| 1                       | Analog Input Data Channel 1 |     |     |     |  |     |     |     |    |    |    |    |    |    |    |    |
| 2                       | Analog Input Data Channel 2 |     |     |     |  |     |     |     |    |    |    |    |    |    |    |    |
| 3                       | Analog Input Data Channel 3 |     |     |     |  |     |     |     |    |    |    |    |    |    |    |    |
| 4                       | Analog Input Data Channel 4 |     |     |     |  |     |     |     |    |    |    |    |    |    |    |    |
| 5                       | Analog Input Data Channel 5 |     |     |     |  |     |     |     |    |    |    |    |    |    |    |    |
| 6                       | Analog Input Data Channel 6 |     |     |     |  |     |     |     |    |    |    |    |    |    |    |    |
| 7                       | Analog Input Data Channel 7 |     |     |     |  |     |     |     |    |    |    |    |    |    |    |    |
| 8                       | OC7                         | OC6 | OC5 | OC4 | OC3  | OC2 | OC1 | OC0 | S7 | S6 | S5 | S4 | S3 | S2 | S1 | S0 |
| 9                       | U7                          | O7  | U6  | O6  | U5   | O5  | U4  | O4  | U3 | O3 | U2 | O2 | U1 | O1 | U0 | O0 |
| 10                      | S8                          | O8  | U8  | OC8 | CJC Value<br>(Degrees C X 10 [0..850 <sub>10</sub> ])<br>(Degrees F X 10 [320..1850 <sub>10</sub> ]) |     |     |     |    |    |    |    |    |    |    |    |

(1) Changing bit values is not supported by all controllers. Refer to your controller manual for details.

## Input Data Values

Data words 0 through 7 correspond to channels 0 through 7 and contain the converted analog input data from the input device. The most significant bit, bit 15, is the sign bit (SGN).

**General Status Bits (S0 to S7)** Bits S0 through S7 of word 8 contain the general status information for channels 0 through 7, respectively. Bit S8 of word 10 contains general status information for the CJC sensor. If set (1), this bit indicates an error (over- or under-range, open-circuit or input data not valid condition) associated with that channel or CJC. The data not valid condition is described below.

### *Input Data Not Valid Condition*

The general status bits S0 to S7 also indicate whether or not the input data for a particular channel, 0 through 7, is being properly converted (valid) by the module. This “invalid data” condition can occur (bit set) when the download of a new configuration to a channel is accepted by the module (proper configuration) but before the A/D converter can provide valid (properly configured) data to the 1769 bus master/controller. The following information highlights the bit operation of the Data Not Valid condition.

1. The default and module power-up bit condition is reset (0).
2. The bit condition is set (1) when a new configuration is received and determined valid by the module. The set (1) bit condition remains until the module begins converting analog data for the previously accepted new configuration. When conversion begins, the bit condition is reset (0). The amount of time it takes for the module to begin the conversion process depends on the number of channels being configured and the amount of configuration data downloaded by the controller.

**NOTE:** If the new configuration is invalid, the bit function remains reset (0) and the module posts a configuration error. See Configuration Errors in chapter 5.

3. If A/D hardware errors prevent the conversion process from taking place, the bit condition is set (1).

### **Open-Circuit Flag Bits (OC0 to OC7)**

Bits OC0 through OC7 of word 8 contain open-circuit error information for channels 0 through 7, respectively. Errors for the CJC sensor are indicated by OC8 of word 10. The bit is set (1) when an open-circuit condition exists.

**Note:** Open circuit detection is applied once every module scan if enabled.

See Open-Circuit Detection in chapter 5 for more information on open-circuit operation.

**Over-Range Flag Bits (O0 to O7)** Over-range bits for channels 0 through 7 are contained in word 9, even-numbered bits. They apply to all input types. When set (1), the over-range flag bit indicates an input signal that is at the maximum of its normal operating range for the represented channel or sensor. The module automatically resets (0) the bit when the data value falls below the maximum for that range. The Over-range bit for the CJC sensor is contained in word 10, bit 14.

### **Under-Range Flag Bits (U0 - U7)**

Under-range bits for channels 0 through 7 are contained in word 9, odd-numbered bits. They apply to all input types. When set (1), the under-range flag bit indicates an input signal that is at the minimum of its normal

operating range for the represented channel or sensor. The module automatically resets (0) the bit when the under-range condition is cleared and the data value is within the normal operating range. The Under-range bit for the CJC sensor is contained in word 10, bit 13.

**Note:** The CJC temperature can be monitored using bits 0 through 11 in input word 10. See table 4.1 for details.

## Module Configuration

After module installation, you must configure operation details, such as input type, data format, etc., for each channel. Configuration data for the module is stored in the controller configuration file, which is both readable and writable.

### Jumper Settings

The module handles many input types and therefore requires the input path be changed when applicable. The module contains jumpers which allow the user to change the input path from current to a non-current path on a channel by channel basis. The jumpers are labeled on the circuit board as J8\_1 through J8\_4 and J9\_1 through J9\_4. When the jumpers are configured across pins 2 and 3 a 250 ohm shunt resistance is applied to the respective channel, which allows for a current type input to be used. When the shunt is configured across pins 1 and 2, the 250 ohm shunt resistance is open, which allows for a non-current type input to be used. Refer to the figures below for proper jumper placement.

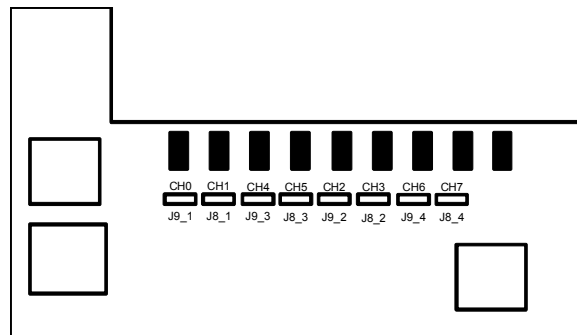

**Note:** The module comes from the factory with all the jumpers set for current type inputs.

### Jumper setting for current type input

This includes all current type inputs (i.e. 0 to 20 mA and 4 to 20 mA)

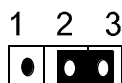

### Jumper setting for non-current type input

Includes input types such as thermocouples, RTDs, resistance and all voltage ranges.

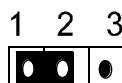

### Module Configuration (Word 0)

Module configuration word C:e.0 contains the bits to enable or disable cyclic calibration and the CJC sensor, for the module. It is also used to indicate which temperature mode is preferred for the module when using RTDs or thermocouples. Disabling cyclic calibration or the CJC sensor (for thermocouple inputs) will reduce the total module scan time if performance over accuracy is desired.



**IMPORTANT** If you are using engineering units x 1

data format and degrees Fahrenheit temperature units, thermocouple types B and C cannot achieve full-scale temperature with 16-bit signed numerical representation. An over-range error will occur for the configured channel if it tries to represent the full-scale value. The maximum representable temperature is 3276.7°F.

The role of the cyclic calibration is to reduce offset and gain drift errors due to temperature changes within the module. By setting bit 14 to 0, you can configure the module to perform calibration on all enabled channels. Setting this bit to 1 disables cyclic calibration.

You can program the calibration cycle to occur whenever you desire for systems that allow modifications to the state of this bit via the ladder program. When the calibration function is enabled (bit = 0), a calibration

cycle occurs once for all enabled channels. If the function remains enabled, a calibration cycle occurs every five minutes thereafter. The calibration cycle of each enabled channel is staggered over several module scan cycles within the five minute period to limit impact on the system response speed.

See Effects of Autocalibration on Module Update Time.

**Note:** The configuration file can also be modified through the control program, if supported by the controller. For information on configuring the module using RSLogix 500 (with MicroLogix 1500 controller), see Appendix E; for RSLogix 5000 (CompactLogix controller), see Appendix F.

The default value of the configuration data is represented by zeros in the data file. The configuration settings for word 0 are shown below.

#### Configuration (Word 0)

| Bit                         | 15 | 14 | 13 | 12 | 11 | 10 | 9 | 8          | 7          | 6          | 5          | 4          | 3          | 2          | 1          | 0          |
|-----------------------------|----|----|----|----|----|----|---|------------|------------|------------|------------|------------|------------|------------|------------|------------|
| <b>Temp Units</b>           |    |    |    |    |    |    |   | <b>CJC</b> | <b>Ch7</b> | <b>Ch6</b> | <b>Ch5</b> | <b>Ch4</b> | <b>Ch3</b> | <b>Ch2</b> | <b>Ch1</b> | <b>Ch0</b> |
| Degrees C                   |    |    |    |    |    |    |   | 0          | 0          | 0          | 0          | 0          | 0          | 0          | 0          | 0          |
| Degrees F                   |    |    |    |    |    |    |   | 1          | 1          | 1          | 1          | 1          | 1          | 1          | 1          | 1          |
| <b>Unused</b>               |    |    |    |    | 0  | 0  | 0 |            |            |            |            |            |            |            |            |            |
| <b>CJC Weighted Profile</b> |    |    |    |    |    |    |   |            |            |            |            |            |            |            |            |            |
| Enabled                     |    |    |    | 0  |    |    |   |            |            |            |            |            |            |            |            |            |
| Disabled                    |    |    |    | 1  |    |    |   |            |            |            |            |            |            |            |            |            |
| <b>CJC Display</b>          |    |    |    |    |    |    |   |            |            |            |            |            |            |            |            |            |
| Disabled                    |    |    | 0  |    |    |    |   |            |            |            |            |            |            |            |            |            |
| Enabled                     |    |    | 1  |    |    |    |   |            |            |            |            |            |            |            |            |            |
| <b>Cyclic Calibration</b>   |    |    |    |    |    |    |   |            |            |            |            |            |            |            |            |            |
| Enabled                     |    | 0  |    |    |    |    |   |            |            |            |            |            |            |            |            |            |
| Disabled                    |    | 1  |    |    |    |    |   |            |            |            |            |            |            |            |            |            |
| <b>CJC Sensor</b>           |    |    |    |    |    |    |   |            |            |            |            |            |            |            |            |            |
| Enabled                     | 0  |    |    |    |    |    |   |            |            |            |            |            |            |            |            |            |
| Disabled                    | 1  |    |    |    |    |    |   |            |            |            |            |            |            |            |            |            |

#### *Temp Units:*

This is applied to the appropriate channel as indicated only if the format selected is Engineering Units X1 or X10. The CJC is only displayed in Engineering units for (0 through 25 °C) [0 .. 850 °C] or [0 .. 1850 °F].

#### *CJC Weighted Profile*

There is only one CJC sensor. If enabled (default), the CJC temperature for each channel is scaled by multiplying the single CJC reading by a predefined scale factor derived from lab measurements of each terminal block pin's stable temperature. If disabled, the single CJC reading is applied directly to all channels. If the CJC sensors are installed in a remote terminal block, the weighted profile must be disabled.



### *CJC Display*

If enabled (default is disabled), all channel data is overridden with that channel's CJC temperature. If disabled, channel data is presented in the input table as normal.

### *Cyclic Calibration*

If enabled (default), the module's internal calibration for the ADC is run once every 5 minutes. If disabled, it is executed only once at power on/reset and not again. Enabling this will allow the module to readjust for environmental changes such as variations in temperature. However, the module throughput is reduced somewhat during the calibration operation. The user may choose to forgo calibration (and its resulting better accuracy over time) in favor of better throughput.

### *CJC Sensor*

If enabled (default), the CJC is read once every other module scan, and its value updated in the CJC status word. This value is also used for thermocouple cold junction compensation. If disabled, the CJC sensor value is not acquired, and the CJC temperature is fixed at 25°C for all channels. The CJC will also be fixed at 25°C for all channels if it is determined to be broken (short or open circuit).

### **Configuration (Word 1)**

| Bit  | 15 | 14 | 13 | 12 | 11 | 10 | 9 | 8 | 7          | 6          | 5          | 4          | 3          | 2          | 1          | 0          |
|--|----|----|----|----|----|----|---|---|------------|------------|------------|------------|------------|------------|------------|------------|
| <b>Open Circuit Disable</b><br>Enabled<br>Disabled           |    |    |    |    |    |    |   |   | <b>Ch7</b> | <b>Ch6</b> | <b>Ch5</b> | <b>Ch4</b> | <b>Ch3</b> | <b>Ch2</b> | <b>Ch1</b> | <b>Ch0</b> |
|  |    |    |    |    |    |    |   |   | 0<br>1     | 0<br>1     | 0<br>1     | 0<br>1     | 0<br>1     | 0<br>1     | 0<br>1     | 0<br>1     |
| <b>0 Volt CJC Adjust</b><br>Perform CJC<br>No CJC Adjustment |    |    |    |    |    |    |   |   | <b>CH7</b> | <b>CH6</b> | <b>CH5</b> | <b>CH4</b> | <b>CH3</b> | <b>CH2</b> | <b>CH1</b> | <b>CH0</b> |
|  |    |    |    |    |    |    |   |   | 0<br>1     | 0<br>1     | 0<br>1     | 0<br>1     | 0<br>1     | 0<br>1     | 0<br>1     | 0<br>1     |

### *Open Circuit Disable*

Setting the bit to 1 disables the open circuit detect for the associated channel.

By default, open circuit detection is applied.

### *0 Volt CJC Adjust*

Cold Junction Compensation (CJC) is performed by default by taking the CJC sensor temperature value for a given channel, converting that to a thermocouple voltage, and adding that voltage from the measured value prior to converting to a user value.

If this bit is set for a given channel, the signal value is directly converted to a user value (No cold junction compensation performed).

### Channel Configuration (Words 2 to 9)

The default value of the configuration data is represented by zeros in the data file. The structure of the channel configuration file is shown below.

| Word/Bit | 15                      | 14                                 | 13          | 12 | 11 | 10         | 9 | 8 | 7 | 6 | 5            | 4                | 3 | 2 | 1                       | 0 |
|----------|-------------------------|------------------------------------|-------------|----|----|------------|---|---|---|---|--------------|------------------|---|---|-------------------------|---|
| 2        | 4 Wire<br>RTD<br>Enable | Cyclic<br>Lead<br>Comp.<br>Disable | Data Format |    |    | Input Type |   |   |   |   | Open Circuit | Filter Frequency |   |   | Disable<br>Channel<br>0 |   |
| 3        | 4 Wire<br>RTD<br>Enable | Cyclic<br>Lead<br>Comp.<br>Disable | Data Format |    |    | Input Type |   |   |   |   | Open Circuit | Filter Frequency |   |   | Disable<br>Channel<br>1 |   |
| 4        | 4 Wire<br>RTD<br>Enable | Cyclic<br>Lead<br>Comp.<br>Disable | Data Format |    |    | Input Type |   |   |   |   | Open Circuit | Filter Frequency |   |   | Disable<br>Channel<br>2 |   |
| 5        | 4 Wire<br>RTD<br>Enable | Cyclic<br>Lead<br>Comp.<br>Disable | Data Format |    |    | Input Type |   |   |   |   | Open Circuit | Filter Frequency |   |   | Disable<br>Channel<br>3 |   |
| 6        | 4 Wire<br>RTD<br>Enable | Cyclic<br>Lead<br>Comp.<br>Disable | Data Format |    |    | Input Type |   |   |   |   | Open Circuit | Filter Frequency |   |   | Disable<br>Channel<br>4 |   |
| 7        | 4 Wire<br>RTD<br>Enable | Cyclic<br>Lead<br>Comp.<br>Disable | Data Format |    |    | Input Type |   |   |   |   | Open Circuit | Filter Frequency |   |   | Disable<br>Channel<br>5 |   |
| 8        | 4 Wire<br>RTD<br>Enable | Cyclic<br>Lead<br>Comp.<br>Disable | Data Format |    |    | Input Type |   |   |   |   | Open Circuit | Filter Frequency |   |   | Disable<br>Channel<br>6 |   |
| 9        | 4 Wire<br>RTD<br>Enable | Cyclic<br>Lead<br>Comp.<br>Disable | Data Format |    |    | Input Type |   |   |   |   | Open Circuit | Filter Frequency |   |   | Disable<br>Channel<br>7 |   |

Each channel configuration word consists of bit fields, the settings of which determine how the channel operates. See the table below and the descriptions that follow for valid configuration settings and their meanings.

| To Select                |                       | Make these bit settings |    |    |    |    |    |   |   |   |   |   |   |   |   |   |   |
|--------------------------|-----------------------|-------------------------|----|----|----|----|----|---|---|---|---|---|---|---|---|---|---|
|                          |                       | 15                      | 14 | 13 | 12 | 11 | 10 | 9 | 8 | 7 | 6 | 5 | 4 | 3 | 2 | 1 | 0 |
| <b>Channel Disable</b>   | Enabled               |                         |    |    |    |    |    |   |   |   |   |   |   |   |   |   | 0 |
|                          | Disabled              |                         |    |    |    |    |    |   |   |   |   |   |   |   |   |   | 1 |
| <b>Filter Frequency</b>  | 60 Hz                 |                         |    |    |    |    |    |   |   |   |   |   |   | 0 | 0 | 0 |   |
|                          | 50 Hz                 |                         |    |    |    |    |    |   |   |   |   |   |   | 0 | 0 | 1 |   |
|                          | 10 Hz                 |                         |    |    |    |    |    |   |   |   |   |   |   | 0 | 1 | 0 |   |
|                          | 250 Hz                |                         |    |    |    |    |    |   |   |   |   |   |   | 0 | 1 | 1 |   |
|                          | 500 Hz                |                         |    |    |    |    |    |   |   |   |   |   |   | 1 | 0 | 0 |   |
|                          | 1 kHz                 |                         |    |    |    |    |    |   |   |   |   |   |   | 1 | 0 | 1 |   |
| <b>Open Circuit</b>      | Upscale               |                         |    |    |    |    |    |   |   |   |   |   | 0 | 0 |   |   |   |
|                          | Downscale             |                         |    |    |    |    |    |   |   |   |   |   | 0 | 1 |   |   |   |
|                          | Last State            |                         |    |    |    |    |    |   |   |   |   |   | 1 | 0 |   |   |   |
|                          | Zero                  |                         |    |    |    |    |    |   |   |   |   |   | 1 | 1 |   |   |   |
| <b>Input Type</b>        | 4 to 20 mA            |                         |    |    |    | 0  | 0  | 0 | 0 | 0 |   |   |   |   |   |   |   |
|                          | 0 to 20 mA            |                         |    |    |    | 0  | 0  | 0 | 0 | 0 | 1 |   |   |   |   |   |   |
|                          | -10 to 10 V           |                         |    |    |    | 0  | 0  | 0 | 0 | 1 | 0 |   |   |   |   |   |   |
|                          | 0 to 10 V             |                         |    |    |    | 0  | 0  | 0 | 0 | 1 | 1 |   |   |   |   |   |   |
|                          | 1 to 5 V              |                         |    |    |    | 0  | 0  | 0 | 1 | 0 | 0 |   |   |   |   |   |   |
|                          | 0 to 5 V              |                         |    |    |    | 0  | 0  | 0 | 1 | 0 | 1 |   |   |   |   |   |   |
|                          | +/-100 mV             |                         |    |    |    | 0  | 0  | 0 | 1 | 1 | 0 |   |   |   |   |   |   |
|                          | +/-50 mV              |                         |    |    |    | 0  | 0  | 0 | 1 | 1 | 1 |   |   |   |   |   |   |
|                          | Type J TC             |                         |    |    |    | 0  | 1  | 0 | 0 | 0 | 0 |   |   |   |   |   |   |
|                          | Type K TC             |                         |    |    |    | 0  | 1  | 0 | 0 | 0 | 1 |   |   |   |   |   |   |
|                          | Type T TC             |                         |    |    |    | 0  | 1  | 0 | 0 | 1 | 0 |   |   |   |   |   |   |
|                          | Type E TC             |                         |    |    |    | 0  | 1  | 0 | 0 | 1 | 1 |   |   |   |   |   |   |
|                          | Type R TC             |                         |    |    |    | 0  | 1  | 1 | 0 | 0 | 0 |   |   |   |   |   |   |
|                          | Type S TC             |                         |    |    |    | 0  | 1  | 1 | 0 | 0 | 1 |   |   |   |   |   |   |
|                          | Type B TC             |                         |    |    |    | 0  | 1  | 1 | 1 | 1 | 0 |   |   |   |   |   |   |
|                          | Type N TC             |                         |    |    |    | 0  | 1  | 1 | 1 | 1 | 1 |   |   |   |   |   |   |
|                          | Type C TC             |                         |    |    |    | 1  | 0  | 0 | 0 | 0 | 0 |   |   |   |   |   |   |
|                          | 100 Pt 385            |                         |    |    |    | 1  | 0  | 0 | 0 | 0 | 1 |   |   |   |   |   |   |
|                          | 200 Pt 385            |                         |    |    |    | 1  | 0  | 0 | 0 | 1 | 0 |   |   |   |   |   |   |
|                          | 500 Pt 385            |                         |    |    |    | 1  | 0  | 0 | 0 | 1 | 1 |   |   |   |   |   |   |
|                          | 1000 Pt 385           |                         |    |    |    | 1  | 0  | 0 | 1 | 0 | 0 |   |   |   |   |   |   |
|                          | 100 Pt 3916           |                         |    |    |    | 1  | 0  | 0 | 1 | 0 | 1 |   |   |   |   |   |   |
|                          | 200 Pt 3916           |                         |    |    |    | 1  | 0  | 0 | 1 | 1 | 0 |   |   |   |   |   |   |
|                          | 500 Pt 3916           |                         |    |    |    | 1  | 0  | 0 | 1 | 1 | 1 |   |   |   |   |   |   |
|                          | 1000 Pt 3916          |                         |    |    |    | 1  | 0  | 0 | 1 | 1 | 1 |   |   |   |   |   |   |
|                          | 10 Cu 426             |                         |    |    |    | 1  | 1  | 0 | 0 | 0 | 1 |   |   |   |   |   |   |
|                          | 120 Ni 618            |                         |    |    |    | 1  | 1  | 0 | 0 | 1 | 0 |   |   |   |   |   |   |
| 120 Ni 672               |                       |                         |    |    | 1  | 1  | 0  | 0 | 1 | 1 |   |   |   |   |   |   |   |
| 604 NiFe 518             |                       |                         |    |    | 1  | 1  | 1  | 0 | 0 | 0 |   |   |   |   |   |   |   |
| 150 ohm                  |                       |                         |    |    | 1  | 1  | 1  | 0 | 0 | 1 |   |   |   |   |   |   |   |
| 1000 ohm                 |                       |                         |    |    | 1  | 1  | 1  | 0 | 0 | 1 |   |   |   |   |   |   |   |
| 3000 ohm                 |                       |                         |    |    | 1  | 1  | 1  | 0 | 0 | 1 |   |   |   |   |   |   |   |
| <b>Data Format</b>       | Engineering Units X1  |                         |    | 0  | 0  | 0  |    |   |   |   |   |   |   |   |   |   |   |
|                          | Engineering Units X10 |                         |    | 0  | 0  | 1  |    |   |   |   |   |   |   |   |   |   |   |
|                          | Raw/Proportional      |                         |    | 0  | 1  | 0  |    |   |   |   |   |   |   |   |   |   |   |
|                          | Scaled for PID        |                         |    | 0  | 1  | 1  |    |   |   |   |   |   |   |   |   |   |   |
|                          | Percent range         |                         |    | 1  | 0  | 0  |    |   |   |   |   |   |   |   |   |   |   |
| <b>Cyclic Lead Comp.</b> | Enable                |                         |    | 0  |    |    |    |   |   |   |   |   |   |   |   |   |   |
|                          | Disable               |                         |    | 1  |    |    |    |   |   |   |   |   |   |   |   |   |   |
| <b>2/4 Wire RTD</b>      | Disable               |                         |    | 0  |    |    |    |   |   |   |   |   |   |   |   |   |   |
|                          | Enable                |                         |    | 1  |    |    |    |   |   |   |   |   |   |   |   |   |   |

**NOTE** Default settings for a particular function are indicated by zero(s). For example, the default filter frequency is 60Hz. Publication

### Enabling 2/4 Wire RTD (Bit 15)

Setting bit 15 to a one enables 2/4 wire RTD on the associated channel.

**Note:** Bits 14 and 15 are used for RTD and resistance modes only. They are used to specify 2, 3, or 4 wire RTD modes. 2-wire RTD mode is implemented when cyclic lead compensation (bit14) is disabled and 2/4-wire(bit15) is enabled 3-wire RTD and resistance is implemented by enabling cyclic lead compensation and disabling 2/4 wire. 4-wire RTD or resistance is implemented by enabling 2/4 wire and disabling cyclic lead compensation.

| Number of Wires | Bit 15 | Bit 14 |
|-----------------|--------|--------|
| 2               | 1      | 0      |
| 3               | 0      | 1 or 0 |
| 4               | 1      | 0      |

### Disabling Cyclic Lead Compensation (Bit 14)

Setting bit 14 to a one disables cyclic lead compensation.

**Note:** Bits 14 and 15 are used for RTD and resistance modes only. They are used to specify 2, 3, or 4 wire RTD modes. 2-wire RTD mode is implemented when cyclic lead compensation (bit14) is disabled and 2/4-wire(bit15) is enabled 3-wire RTD and resistance is implemented by enabling cyclic lead compensation and disabling 2/4 wire. 4-wire RTD or resistance is implemented by enabling 2/4 wire and disabling cyclic lead compensation.

| Number of Wires | Bit 15 | Bit 14 |
|-----------------|--------|--------|
| 2               | 1      | 0      |
| 3               | 0      | 1 or 0 |
| 4               | 1      | 0      |

### Selecting Data Formats (Bits 13 through 11)

This selection configures channels 0 through 7 to present analog data in any of the following formats:

Engineering Units x 1

Engineering Units x 10

Raw/Proportional Data

Scaled for PID

Percent Range

Table 4.2 Channel Data Word Format

| Input Type      | Data Format                |                            |                              |                              |                |                     |               |
|-----------------|----------------------------|----------------------------|------------------------------|------------------------------|----------------|---------------------|---------------|
|                 | Engineering Units x 10     |                            | Engineering Units x 1        |                              | Scaled For PID | Proportional Counts | Percent Range |
|                 | ? Celsius                  | ? Fahrenheit               | ? Celsius                    | ? Fahrenheit                 |                |                     |               |
| J               | -210 to 1200               | -346 to 2192               | -2100 to 12000               | -3460 to 21920               | 0 to 16383     | -32767 to 32767     | 0 to +10000   |
| K               | -270 to 1370               | -454 to 2498               | -2700 to 13700               | -4540 to 24980               | 0 to 16383     | -32767 to 32767     | 0 to +10000   |
| T               | -270 to 400                | -454 to 752                | -2700 to 4000                | -4540 to 7520                | 0 to 16383     | -32767 to 32767     | 0 to +10000   |
| E               | -270 to 1000               | -454 to 1832               | -2700 to 10000               | -4540 to 18320               | 0 to 16383     | -32767 to 32767     | 0 to +10000   |
| R               | 0 to 1768                  | 32 to 3214                 | 0 to 17680                   | 320 to 32140                 | 0 to 16383     | -32767 to 32767     | 0 to +10000   |
| S               | 0 to 1768                  | 32 to 3214                 | 0 to 17680                   | 320 to 32140                 | 0 to 16383     | -32767 to 32767     | 0 to +10000   |
| B               | 300 to 1820                | 572 to 3308                | 3000 to 18200                | 5720 to 32767 <sup>1</sup>   | 0 to 16383     | -32767 to 32767     | 0 to +10000   |
| N               | -210 to 1300               | -346 to 2372               | -2100 to 13000               | -3460 to 23720               | 0 to 16383     | -32767 to 32767     | 0 to +10000   |
| C               | 0 to 2315                  | 32 to 4199                 | 0 to 23150                   | 320 to 32767 <sup>1</sup>    | 0 to 16383     | -32767 to 32767     | 0 to +10000   |
| +/- 50 mV       | -500 to 500 <sup>2</sup>   | -500 to 500 <sup>2</sup>   | -5000 to 5000 <sup>2</sup>   | -5000 to 5000 <sup>2</sup>   | 0 to 16383     | -32767 to 32767     | 0 to +10000   |
| +/- 100 mV      | -1000 to 1000 <sup>2</sup> | -1000 to 1000 <sup>2</sup> | -10000 to 10000 <sup>2</sup> | -10000 to 10000 <sup>2</sup> | 0 to 16383     | -32767 to 32767     | 0 to +10000   |
| 0 – 5 V         | 0 to 500 <sup>2</sup>      | 0 to 500 <sup>2</sup>      | 0 to 5000 <sup>2</sup>       | 0 to 5000 <sup>2</sup>       | 0 to 16383     | -32767 to 32767     | 0 to +10000   |
| 1 – 5 V         | 100 to 500 <sup>2</sup>    | 100 to 500 <sup>2</sup>    | 1000 to 5000 <sup>2</sup>    | 1000 to 5000 <sup>2</sup>    | 0 to 16383     | -32767 to 32767     | 0 to +10000   |
| 0 – 10 V        | 0 to 1000 <sup>2</sup>     | 0 to 1000 <sup>2</sup>     | 0 to 10000 <sup>2</sup>      | 0 to 10000 <sup>2</sup>      | 0 to 16383     | -32767 to 32767     | 0 to +10000   |
| +/- 10 V        | -1000 to 1000 <sup>2</sup> | -1000 to 1000 <sup>2</sup> | -10000 to 10000 <sup>2</sup> | -10000 to 10000 <sup>2</sup> | 0 to 16383     | -32767 to 32767     | 0 to +10000   |
| 0 – 20 mA       | 0 to 2000 <sup>2</sup>     | 0 to 2000 <sup>2</sup>     | 0 to 20000 <sup>2</sup>      | 0 to 20000 <sup>2</sup>      | 0 to 16383     | -32767 to 32767     | 0 to +10000   |
| 4 – 20 mA       | 400 to 2000 <sup>2</sup>   | 400 to 2000 <sup>2</sup>   | 4000 to 20000 <sup>2</sup>   | 4000 to 20000 <sup>2</sup>   | 0 to 16383     | -32767 to 32767     | 0 to +10000   |
| 0 – 150 Ω       | 0 to 150                   | 0 to 150                   | 0 to 1500                    | 0 to 1500                    | 0 to 16383     | -32767 to 32767     | 0 to +10000   |
| 0 – 1000 Ω      | 0 to 1000                  | 0 to 1000                  | 0 to 10000                   | 0 to 10000                   | 0 to 16383     | -32767 to 32767     | 0 to +10000   |
| 0 – 3000 Ω      | 0 to 3000                  | 0 to 3000                  | 0 to 30000                   | 0 to 30000                   | 0 to 16383     | -32767 to 32767     | 0 to +10000   |
| Platinum 385    | -200 to 850                | -328 to 1562               | -2000 to 8500                | -3280 to 15620               | 0 to 16383     | -32767 to 32767     | 0 to +10000   |
| Platinum 3916   | -200 to 630                | -328 to 1166               | -2000 to 6300                | -3280 to 11660               | 0 to 16383     | -32767 to 32767     | 0 to +10000   |
| Copper 426      | -100 to 260                | -148 to 500                | -1000 to 2600                | -1480 to 5000                | 0 to 16383     | -32767 to 32767     | 0 to +10000   |
| Nickel 618      | -100 to 260                | -148 to 500                | -1000 to 2600                | -1480 to 5000                | 0 to 16383     | -32767 to 32767     | 0 to +10000   |
| Nickel 672      | -80 to 260                 | -112 to 500                | -800 to 2600                 | -1120 to 5000                | 0 to 16383     | -32767 to 32767     | 0 to +10000   |
| Nickel-Iron 518 | -100 to 200                | -148 to 392                | -1000 to 2000                | -1480 to 3920                | 0 to 16383     | -32767 to 32767     | 0 to +10000   |

<sup>1</sup> Type B and C thermocouples, Nickel 672, Nickel 618, Nickel-Iron 518, and Copper 426 cannot be represented in engineering units x 1 (°F) above 3276.7°F (or below -3276.7°F for Nickel-Iron 518). Software treats it as an over range error (or under range error for below -3276.7°F for Nickel-Iron 518).

<sup>2</sup> When voltage or current modes are selected, the temperature setting is ignored. Analog input data is the same for either °C or °F selection.

**NOTE** The engineering units data formats represent real engineering temperature units provided by the module to the controller. The raw/proportional counts, scaled-for-PID and percent of full-scale data formats may yield the highest effective resolutions, but may also require that you convert channel data to real engineering units in your control program.

#### *Raw/Proportional Data*

The value presented to the controller is proportional to the selected input and scaled into the maximum data range allowed by the bit resolution of the A/D converter and filter selected. The raw/proportional data format also provides the best resolution of all the data formats.

If you select the raw/proportional data format for a channel, the data word will be a number between -32767 and +32767. For example, if a type J thermocouple is selected, the lowest temperature of -210°C corresponds to -32767 counts. The highest temperature of 1200°C corresponds to

+32767. See Determining Effective Resolution and Range within this chapter.

#### *Engineering Units x 1*

When using this data format, the module scales the input data to the actual engineering values for the selected input type. Values are expressed with an assumed decimal place. Refer to Table 4.2 for details.

**NOTE** Use the engineering units x 10 setting to produce temperature readings in whole degrees Celsius or Fahrenheit.

The resolution of the engineering units x 1 data format is dependent on the range selected and the filter selected. See Determining Effective Resolution and Range.

#### *Engineering Units x 10*

When using this data format, the module scales the input data to the actual engineering values for the selected input type. Values are expressed in whole units (i.e. no assumed decimal place) Refer to table 4.2 for more details.

The resolution of the engineering units x 10 data format is dependent on the range selected and the filter selected. See Determining Effective Resolution and Range.

#### *Scaled-for-PID*

The value presented to the controller is a signed integer with 0 representing the lower input range and +16383 representing the upper input range.

To obtain the value, the module scales the input signal range to a 0 to +16383 range, which is standard to the PID algorithm for the MicroLogix 1500 and other Allen-Bradley controllers (e.g. SLC). For example, if type J thermocouple is used, the lowest temperature for the thermocouple is -210°C, which corresponds to 0 counts. The highest temperature in the input range, 1200°C, corresponds to +16383 counts.

#### *Percent Range*

Input data is presented to the user as a percent of the specified range. The module scales the input signal range to a 0 to +10000 range. For example, using a type J thermocouple, the range -210°C to +1200°C is represented as 0% to 100%. See Determining Effective Resolution and Range.

### Selecting Input Type (Bits 10 through 6)

Bits 10 through 6 in the channel configuration word indicate the type of input device. If channels 1, 3, 5, or 7 are configured for RTD or Resistance type, the configuration for the following even channels (2, 4, 6, 8) are ignored, respectively. It is recommended to set both channels identically (1 and 2, 3 and 4, 5 and 6, or 7 and 8) when setting a channel to RTD or Resistance mode. This reduces confusion in the setup. A zero will be reported, in the input data word, for the respective even channel in RTD mode to reflect the RTD or resistance mode configuration. The 4-20 mA range is the default input type for each channel.

**Note:** The on-board jumpers must be changed to voltage mode if any other input type is desired other than current.

### Determining Open-Circuit Response (Bits 5 and 4)

An open-circuit condition occurs when an input device or its extension wire is physically separated or open. This can happen if the wire is cut or disconnected from the terminal block.

**NOTE:** If the CJC sensor is removed from the module terminal block, its open-circuit bit is set (1) and the module continues to calculate thermocouple readings at reduced accuracy. If an open CJC circuit is detected, the module uses 25°C as the sensed temperature at that location. Channels that are configured for other input types are not affected by CJC open-circuit conditions. See Open-Circuit Detection in chapter 5 for additional details.

Bits 5 and 4 define the state of the channel data word when an open-circuit or short circuit condition is detected for the corresponding channel. The module overrides the actual input data depending on the option that you specify when it detects an open circuit. The open-circuit options are explained in the table below.

| Response Option   | Definition   |
|-------------------|--|
| Upscale           | Sets the input data value to full upper scale value of channel data word. The full-scale value is determined by the selected input type and data format. |
| Downscale         | Sets the input data value to full lower scale value of channel data word. The low scale value is determined by the selected input type and data format.  |
| Last State        | Sets the input data value to the last input value prior to the detection of the open-circuit.  |
| Zero <sup>1</sup> | Sets the input data value to 0 to force the channel data word to 0.  |

<sup>1</sup> If 0 is out-of-range for the selected input type, the data value will default to minimum scale on open circuit.

### Selecting Input Filter Frequency (Bits 3 through 1)

The input filter selection field allows you to select the filter frequency for each channel and provides system status of the input filter setting for channels 0 through 7. The filter frequency affects the following, as explained later in this chapter:

noise rejection characteristics for module inputs

channel step response

channel cut-off frequency

effective resolution

module update time

#### *Effects of Filter Frequency on Noise Rejection*

The filter frequency that you choose for a module channel determines the amount of noise rejection for the inputs. A lower frequency (50 Hz versus 500 Hz) provides better noise rejection and increases effective resolution, but also increases channel update time. A higher filter frequency provides lower noise rejection, but decreases the channel update time and effective resolution.

When selecting a filter frequency, be sure to consider cut-off frequency and channel step response to obtain acceptable noise rejection. Choose a filter frequency so that your fastest-changing signal is below that of the filter's cut-off frequency.

Common Mode Rejection is better than 115 dB at 50 and 60 Hz, with the 50 and 60 Hz filters selected, respectively, or with the 10Hz filter selected. The module performs well in the presence of common mode noise as long as the signals applied to the user positive and negative input terminals do not exceed the common mode voltage rating ( $\pm 10V$ ) of the module. Improper earth ground may be a source of common mode noise.

**NOTE:** Transducer power supply noise, transducer circuit noise, or process variable irregularities may also be sources of normal mode noise.

**NOTE:** The filter frequency of the module's CJC sensors is the lowest filter frequency of any enabled thermocouple type to maximize the trade-offs between effective resolution and channel update time.

#### *Effects of Filter Frequency on Channel Step Response*

The selected channel filter frequency determines the channel's step response. The step response is the time required for the analog input signal



to reach 100% of its expected final value, given a full-scale step change in the input signal. This means that if an input signal changes faster than the channel step response, a portion of that signal will be attenuated by the channel filter. The channel step response is calculated by a settling time of  $3 \times (1/\text{filter frequency})$ .

**Table 4.4 Filter Frequency and Step Response**

| <b>Filter Frequency</b> | <b>Step Response</b> |
|-------------------------|----------------------|
| 10 Hz                   | 300 ms               |
| 50 Hz                   | 60 ms                |
| 60 Hz                   | 50 ms                |
| 250 Hz                  | 12 ms                |
| 500 Hz                  | 6 ms                 |
| 1 KHz                   | 3 ms                 |

#### *Channel Cut-Off Frequency*

The filter cut-off frequency, -3 dB, is the point on the frequency response curve where frequency components of the input signal are passed with 3 dB of attenuation. The following table shows cut-off frequencies for the supported filters.

**Table 4.5 Filter Frequency versus Channel Cut-off Frequency**

| <b>Filter Frequency</b> | <b>Cut-off Frequency</b> |
|-------------------------|--------------------------|
| 10 Hz                   | 2.62 Hz                  |
| 50 Hz                   | 13.1 Hz                  |
| 60 Hz                   | 15.7 Hz                  |
| 250 Hz                  | 65.5 Hz                  |
| 500 Hz                  | 131 Hz                   |
| 1 KHz                   | 262 Hz                   |

All input frequency components at or below the cut-off frequency are passed by the digital filter with less than 3 dB of attenuation. All frequency components above the cut-off frequency are increasingly attenuated as shown in the graphs on the next page.

**Figure 4.1 Frequency Response Graphs**

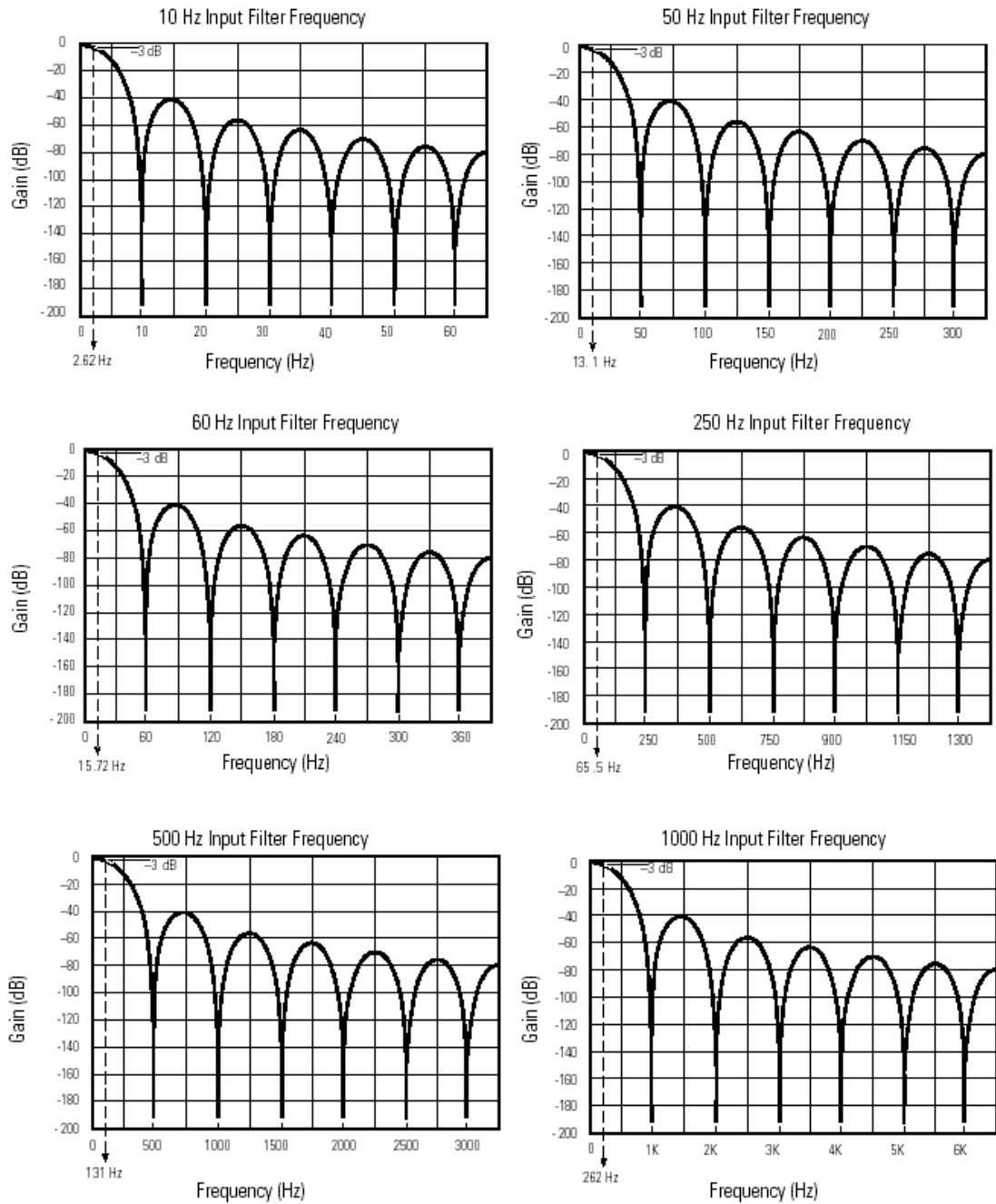

The cut-off frequency for each channel is defined by its filter frequency selection. Choose a filter frequency so that your fastest changing signal is

---

below that of the filter's cut-off frequency. The cut-off frequency should not be confused with the update time. The cut-off frequency relates to how the digital filter attenuates frequency components of the input signal.

The update time defines the rate at which an input channel is scanned and its channel data word is updated.

#### **Enabling or Disabling a Channel (Bit 0)**

You can enable or disable each of the six channels individually using bit 15. The module only scans enabled channels. Enabling a channel forces it to be recalibrated before it measures input data. Disabling a channel sets the channel data word to zero.

**NOTE** When a channel is not enabled (0), no input is provided to the controller by the A/D converter. This speeds up the response of the active channels, improving performance.

#### **Channel Configuration (Words 10 to 17)**

RESERVED



Attention! Words 10 through 17 must be set to zero.

---

## Determining Effective Resolution and Range

The effective resolution for an input channel depends upon the filter frequency selected for that channel. The following tables provide the effective resolution for each of the range selections at the six available frequencies. The tables do not include the affects of unfiltered input noise. Choose the frequency that most closely matches your requirements.

**Table 4.6a Effective Resolution(In counts) vs. Input Filter Selection**

| Input Type       | Raw/Proportional Counts |      |      |       |       |        |
|------------------|-------------------------|------|------|-------|-------|--------|
|                  | 60Hz                    | 50Hz | 10Hz | 250Hz | 500Hz | 1000Hz |
| 4to20mA          | 1                       | 2    | 1    | 8     | 33    | 201    |
| 0to20mA          | 1                       | 1    | 1    | 12    | 33    | 268    |
| -10V to +10V     | 0                       | 0    | 0    | 3     | 6     | 48     |
| 0to10V           | 1                       | 0    | 1    | 2     | 16    | 96     |
| 1to5V            | 1                       | 1    | 0    | 3     | 21    | 80     |
| 0to5V            | 1                       | 1    | 0    | 5     | 16    | 65     |
| -100mV to +100mV | 1                       | 1    | 1    | 14    | 40    | 160    |
| -50mV to +50mV   | 2                       | 1    | 1    | 13    | 46    | 61     |
| Type J-TC        | 4                       | 4    | 2    | 35    | 71    | 209    |
| Type K-TC        | 12                      | 7    | 6    | 58    | 162   | 761    |
| Type T-TC        | 63                      | 72   | 41   | 548   | 863   | 2036   |
| Type E-TC        | 8                       | 8    | 5    | 34    | 123   | 625    |
| Type R-TC        | 14                      | 18   | 11   | 120   | 365   | 1104   |
| Type S-TC        | 17                      | 16   | 6    | 112   | 381   | 928    |
| Type B-TC        | 31                      | 28   | 17   | 175   | 805   | 1633   |
| Type N-TC        | 5                       | 7    | 3    | 39    | 102   | 319    |
| Type C-TC        | 6                       | 6    | 3    | 60    | 162   | 341    |
| 100 Pt 385       | 3                       | 2    | 1    | 17    | 51    | 408    |
| 200 Pt 385       | 1                       | 0    | 1    | 7     | 16    | 93     |
| 500 Pt 385       | 1                       | 0    | 0    | 3     | 57    | 514    |
| 1000 Pt 385      | 1                       | 1    | 0    | 3     | 10    | 332    |
| 100 Pt 3916      | 3                       | 2    | 1    | 26    | 21    | 684    |
| 200 Pt 3916      | 1                       | 2    | 1    | 12    | 20    | 156    |
| 500 Pt 3916      | 1                       | 1    | 0    | 6     | 83    | 453    |
| 1000 Pt 3916     | 0                       | 1    | 0    | 7     | 24    | 63     |
| 10 Cu 426        | 50                      | 40   | 14   | 149   | 206   | 1647   |
| 120 Ni 618       | 2                       | 3    | 1    | 30    | 21    | 518    |
| 120 Ni 672       | 2                       | 2    | 1    | 23    | 27    | 261    |
| 604 NiFe 518     | 1                       | 1    | 0    | 10    | 35    | 631    |
| 150 ohm          | 5                       | 5    | 2    | 20    | 107   | 1372   |
| 1000 ohm         | 1                       | 2    | 1    | 7     | 39    | 102    |
| 3000 ohm         | 1                       | 0    | 0    | 10    | 21    | 68     |

Note: A 1000 samples were taken to find the deviations listed above.

**Table 4.6b Effective Resolution(In units) vs. Input Filter Selection**

| Input Type       | Units (V,A,degC,Ohms) |          |          |          |           |           |
|------------------|-----------------------|----------|----------|----------|-----------|-----------|
|                  | 60Hz                  | 50Hz     | 10Hz     | 250Hz    | 500Hz     | 1000Hz    |
| 4to20mA          | 0.000000              | 0.000000 | 0.000000 | 0.000002 | 0.000008  | 0.000049  |
| 0to20mA          | 0.000000              | 0.000000 | 0.000000 | 0.000004 | 0.000010  | 0.000082  |
| -10V to +10V     | 0.000000              | 0.000000 | 0.000000 | 0.000915 | 0.001830  | 0.014640  |
| 0to10V           | 0.000153              | 0.000000 | 0.000153 | 0.000306 | 0.002448  | 0.014688  |
| 1to5V            | 0.000061              | 0.000061 | 0.000000 | 0.000183 | 0.001281  | 0.004880  |
| 0to5V            | 0.000076              | 0.000076 | 0.000000 | 0.000382 | 0.001221  | 0.004960  |
| -100mV to +100mV | 0.000003              | 0.000003 | 0.000003 | 0.000043 | 0.000122  | 0.000488  |
| -50mV to +50mV   | 0.000003              | 0.000002 | 0.000002 | 0.000020 | 0.000070  | 0.000093  |
| Type J-TC        | 0.086000              | 0.086000 | 0.043000 | 0.752500 | 1.526500  | 4.493500  |
| Type K-TC        | 0.301200              | 0.175700 | 0.150600 | 1.455800 | 4.066200  | 19.101100 |
| Type T-TC        | 0.642600              | 0.734400 | 0.418200 | 5.589600 | 8.802600  | 20.767200 |
| Type E-TC        | 0.155200              | 0.155200 | 0.097000 | 0.659600 | 2.386200  | 12.125000 |
| Type R-TC        | 0.378000              | 0.486000 | 0.297000 | 3.240000 | 9.855000  | 29.808000 |
| Type S-TC        | 0.459000              | 0.432000 | 0.162000 | 3.024000 | 10.287000 | 25.056000 |
| Type B-TC        | 0.719200              | 0.649600 | 0.394400 | 4.060000 | 18.676000 | 37.885600 |
| Type N-TC        | 0.115000              | 0.161000 | 0.069000 | 0.897000 | 2.346000  | 7.337000  |
| Type C-TC        | 0.211800              | 0.211800 | 0.105900 | 2.118000 | 5.718600  | 12.037300 |
| 100 Pt 385       | 0.048000              | 0.032000 | 0.016000 | 0.272000 | 0.816000  | 6.528000  |
| 200 Pt 385       | 0.016000              | 0.000000 | 0.016000 | 0.112000 | 0.256000  | 1.488000  |
| 500 Pt 385       | 0.016000              | 0.000000 | 0.000000 | 0.048000 | 0.912000  | 8.224000  |
| 1000 Pt 385      | 0.016000              | 0.016000 | 0.000000 | 0.048000 | 0.160000  | 5.312000  |
| 100 Pt 3916      | 0.038100              | 0.025400 | 0.012700 | 0.330200 | 0.266700  | 8.686800  |
| 200 Pt 3916      | 0.012700              | 0.025400 | 0.012700 | 0.152400 | 0.254000  | 1.981200  |
| 500 Pt 3916      | 0.012700              | 0.012700 | 0.000000 | 0.076200 | 1.054100  | 5.753100  |
| 1000 Pt 3916     | 0.000000              | 0.012700 | 0.000000 | 0.088900 | 0.304800  | 0.800100  |
| 10 Cu 426        | 0.274500              | 0.219600 | 0.076860 | 0.818010 | 1.130940  | 9.042030  |
| 120 Ni 618       | 0.010980              | 0.016470 | 0.005490 | 0.164700 | 0.115290  | 2.843820  |
| 120 Ni 672       | 0.010380              | 0.010380 | 0.005190 | 0.119370 | 0.140130  | 1.354590  |
| 604 NiFe 518     | 0.004580              | 0.004580 | 0.000000 | 0.045800 | 0.160300  | 2.889980  |
| 150 ohm          | 0.011400              | 0.011400 | 0.004560 | 0.045600 | 0.243960  | 3.128160  |
| 1000 ohm         | 0.015300              | 0.030600 | 0.015300 | 0.107100 | 0.596700  | 1.560600  |
| 3000 ohm         | 0.045800              | 0.000000 | 0.000000 | 0.458000 | 0.961800  | 3.114400  |

## Determining Module Update Time

The module update time is defined as the time required for the module to sample and convert the input signals of all enabled input channels and provide the resulting data values to the processor. Module update time can be calculated by adding the sum of all enabled channel's times. The module sequentially samples the enabled channels in a continuous loop.

Channel update time is dependent upon the input filter selection. The following table shows the channel update times.

**Table 4.7 Channel Update**

| <b>Filter Frequency</b> | <b>Channel Update Time</b> |
|-------------------------|----------------------------|
| 10 Hz                   | 305 ms                     |
| 50 Hz                   | 66 ms                      |
| 60 Hz                   | 56 ms                      |
| 250 Hz                  | 18 ms                      |
| 500 Hz                  | 12 ms                      |
| 1 KHz                   | 9 ms                       |

The CJC input is only sampled if one or more channels are enabled for any thermocouple type. The CJC update time is equal to the largest channel update time of any of the enabled thermocouple inputs types. In that case, a single CJC update is done per scan. The cyclic calibration time only applies when cyclic calibration is enabled and active. If enabled, the cyclic calibration is staggered over several scan cycles once every five minutes to limit the overall impact of the module update time.

### Effects of Autocalibration on Module Update Time

The module's autocalibration feature allows it to correct for accuracy errors caused by temperature drift over the module operating temperature range (0 to 60°C). Autocalibration occurs automatically on a system mode change from Program-to-Run for all configured channels or if any online(1) configuration change is made to a channel. In addition, you can configure the module to perform autocalibration every 5 minutes during normal operation, or you can disable this feature using the Enable/ Disable Cyclic Calibration function (default is enabled). This feature allows you to implement a calibration cycle anytime, at your command, by enabling and then disabling this bit.(1)

(1) Not all controllers allow online configuration changes. Refer to your controller's user manual for details. During an online configuration change, input data for the affected channel is not updated by the module.

If you enable the cyclic autocalibration function, the module update time increases when the autocalibration occurs. To limit its impact on the module update time, the autocalibration function is divided over two module scans. The first part (offset/0) of a channel calibration adds 73 ms and the second part (gain/span) adds 101 ms to the module update. This takes place over two consecutive module scans. Each enabled channel requires a separate offset/0 and gain/span cycle, unless *any* channel to be scanned uses an Input Type of the same Input Class as *any previously calibrated* channel. In that case, offset and gain calibration values from the previous channel are used, and no additional time is required.

### Calculating Module Update Time

To determine the module update time, add the individual channel update times for each enabled channel and the CJC update time if any of the channels are enabled as thermocouple inputs.

#### EXAMPLE 1. Two Channels Enabled for Millivolt Inputs

Channel 0:  $\pm 50$  mV with 60 Hz filter  
 Channel 1 Input:  $\pm 50$  mV with 500 Hz filter  
 From Table 4.7, Channel Update Time:

#### Module Update Time

= Ch 0 Update Time + Ch 1 Update Time  
 = 56 ms + 12 ms  
 = 68 ms

#### EXAMPLE 2. Three Channels Enabled for Different Inputs

Channel 0 Input: Type J Thermocouple with 10 Hz filter  
 Channel 1 Input: Type J Thermocouple with 60 Hz filter  
 Channel 2 Input:  $\pm 100$  mV with 250 Hz filter  
 From Table 4.7, Channel Update Time:

#### Module Update Time

= Ch 0 Update Time + Ch 1 Update Time  
 + Ch 2 Update Time + CJC Update Time (uses lowest thermocouple filter selected)  
 = 305 ms + 56 ms + 18 ms + 305 ms  
 = 684 ms

#### EXAMPLE 3. Three Channels Enabled for Different Inputs with Cyclic Calibration Enabled

Channel 0 Input: Type T Thermocouple with 60 Hz Filter  
 Channel 1 Input: Type T Thermocouple with 60 Hz Filter  
 Channel 2 Input: Type J Thermocouple with 60 Hz Filter

From Table 4.7, Channel Update Time:

**Module Update Time *without* an Autocalibration Cycle**

$$\begin{aligned}
 &= \text{Ch 0 Update Time} + \text{Ch 1 Update Time} \\
 &+ \text{Ch 2 Update Time} + \text{CJC Update Time (uses lowest thermocouple filter} \\
 &\text{selected)} \\
 &= 56 \text{ ms} + 56 \text{ ms} + 56 \text{ ms} + 56 \text{ ms} = 224 \text{ ms}
 \end{aligned}$$

**Module Update Time *during* an Autocalibration Cycle**

**Channel 0 Scan 1 (Module Scan 1)**

$$\begin{aligned}
 &= \text{Ch 0 Update Time} + \text{Ch 1 Update Time} \\
 &+ \text{Ch 2 Update Time} + \text{CJC Update Time} + \text{Ch 0 Gain Time} \\
 &= 56 \text{ ms} + 56 \text{ ms} + 56 \text{ ms} + 56 \text{ ms} + 101 \text{ ms} = 325 \text{ ms}
 \end{aligned}$$

**Channel 0 Scan 3 (Module Scan 2)**

$$\begin{aligned}
 &= \text{Ch 0 Update Time} + \text{Ch 1 Update Time} \\
 &+ \text{Ch 2 Update Time} + \text{CJC Update Time} + \text{Ch 0 Offset Time} \\
 &= 56 \text{ ms} + 56 \text{ ms} + 56 \text{ ms} + 56 \text{ ms} + 73 \text{ ms} = 297 \text{ ms}
 \end{aligned}$$

**Channel 1 Scan 1 : (no scan impact)**

No autocalibration cycle is required because Channel 1 is the same Input Class as Channel 0. Data is updated in scan 3.

**Channel 2, Scan 1 (Module Scan 3)**

$$\begin{aligned}
 &= \text{Ch 0 Update Time} + \text{Ch 1 Update Time} \\
 &+ \text{Ch 2 Update Time} + \text{CJC Update Time} + \text{Ch 2 Gain Time} \\
 &= 56 \text{ ms} + 56 \text{ ms} + 56 \text{ ms} + 56 \text{ ms} + 101 \text{ ms} = 325 \text{ ms}
 \end{aligned}$$

**Channel 2, Scan 2 (Module Scan 4)**

$$\begin{aligned}
 &= \text{Ch 0 Update Time} + \text{Ch 1 Update Time} \\
 &+ \text{Ch 2 Update Time} + \text{CJC Update Time} + \text{Ch 2 Offset Time} \\
 &= 56 \text{ ms} + 56 \text{ ms} + 56 \text{ ms} + 56 \text{ ms} + 73 \text{ ms} = 297 \text{ ms}
 \end{aligned}$$

**CJC Scan 1 (Module Scan 5)**

$$\begin{aligned}
 &= \text{Ch 0 Update Time} + \text{Ch 1 Update Time} \\
 &+ \text{Ch 2 Update Time} + \text{CJC Update Time} + \text{CJC Gain Time} \\
 &= 56 \text{ ms} + 56 \text{ ms} + 56 \text{ ms} + 56 \text{ ms} + 101 \text{ ms} = 325 \text{ ms}
 \end{aligned}$$

**CJC Scan 2 (Module Scan 6)**

$$\begin{aligned}
 &= \text{Ch 0 Update Time} + \text{Ch 1 Update Time} \\
 &+ \text{Ch 2 Update Time} + \text{CJC Update Time} + \text{CJC Offset Time} \\
 &= 56 \text{ ms} + 56 \text{ ms} + 56 \text{ ms} + 56 \text{ ms} + 73 \text{ ms} = 297 \text{ ms}
 \end{aligned}$$

After the above cycles are complete, the module returns to scans without autocalibration for approximately 5 minutes. At that time, the autocalibration cycle repeats.



### Impact of Autocalibration on Module Startup During Mode Change

Regardless of the selection of the Enable/Disable Cyclic Calibration function, an autocalibration cycle occurs automatically on a mode change from Program-to-Run and on subsequent module startups/initialization for all configured channels. During module startup, input data is not updated by the module and the General Status bits (S0 to S7) are set to 1, indicating a Data Not Valid condition. The amount of time it takes the module to startup is dependent on channel filter frequency selections as indicated in Table 4.7, Channel Update Time. The following is an example calculation of module startup time.

#### EXAMPLE 1. Two Channels Enabled for Different Inputs

Channel 0 Input: Type T Thermocouple with 60 Hz filter

Channel 1 Input: Type J Thermocouple with 60 Hz filter

#### Module Startup Time

$$\begin{aligned} &= (\text{Ch 0 Gain Time} + \text{Ch 0 Offset Time}) + (\text{Ch 1 Gain Time} + \text{Ch 1 Offset Time}) \\ &+ (\text{CJC Gain Time} + \text{CJC Offset Time}) + (\text{CJC Data Acquisition} + \text{Ch 0 Data Acquisition} + \text{Ch 1 Data Acquisition}) \\ &= (101 \text{ ms} + 73 \text{ ms}) + (101 \text{ ms} + 73 \text{ ms}) + (101 \text{ ms} + 73 \text{ ms}) + (56 \text{ ms} + 56 \text{ ms}) \\ &= 174 \text{ ms} + 174 \text{ ms} + 174 \text{ ms} + 168 \text{ ms} = 690 \text{ ms} \end{aligned}$$



# Chapter 5

## Diagnostics and Troubleshooting

This chapter describes troubleshooting the universal input module. This chapter contains information on:

safety considerations while troubleshooting

internal diagnostics during module operation

module errors

contacting Spectrum Controls, Inc. for technical assistance

### Safety Considerations

Safety considerations are an important element of proper troubleshooting procedures. Actively thinking about the safety of yourself and others, as well as the condition of your equipment, is of primary importance.

The following sections describe several safety concerns you should be aware of when troubleshooting your control system.



**ATTENTION! Never reach into a machine to actuate a switch because unexpected motion can occur and cause injury. Remove all electrical power at the main power disconnect switches before checking electrical connections or inputs/ outputs causing machine motion.**

---

#### **Indicator Lights**

When the green LED on the module is illuminated, it indicates that power is applied to the module and that it has passed its internal tests.

#### **Stand Clear of Equipment**

When troubleshooting any system problem, have all personnel remain clear of the equipment. The problem could be intermittent, and sudden unexpected machine motion could occur. Have someone ready to operate an emergency stop switch in case it becomes necessary to shut off power.

#### **Program Alteration**

There are several possible causes of alteration to the user program, including extreme environmental conditions, Electromagnetic Interference

(EMI), improper grounding, improper wiring connections, and unauthorized tampering. If you suspect a program has been altered, check it against a previously saved master program.

### **Safety Circuits**

Circuits installed on the machine for safety reasons, like over-travel limit switches, stop push buttons, and interlocks, should always be hard-wired to the master control relay. These devices must be wired in series so that when any one device opens, the master control relay is de-energized, thereby removing power to the machine. Never alter these circuits to defeat their function. Serious injury or machine damage could result.

## Module Operation vs. Channel Operation

The module performs diagnostic operations at both the module level and the channel level. Module-level operations include functions such as power-up, configuration, and communication with a 1769 bus master, such as a MicroLogix 1500 controller, 1769-ADN DeviceNet Adapter, or CompactLogix controller.

Channel-level operations describe channel related functions, such as data conversion and over- or under-range detection.

Internal diagnostics are performed at both levels of operation. When detected, module error conditions are immediately indicated by the module status LED. Both module hardware and channel configuration error conditions are reported to the controller. Channel over-range or under-range and open-circuit conditions are reported in the module's input data table. Module hardware errors are typically reported in the controller's I/O status file. Refer to your controller manual for details.

## Power-up Diagnostics

At module power-up, a series of internal diagnostic tests are performed. If these diagnostic tests are not successfully completed, the module status LED remains off and a module error is reported to the controller.

| If module status LED is: | Indicated condition | Corrective action:   |
|--------------------------|---------------------|--|
| On                       | Proper Operation    | No action required   |
| Off                      | Module Fault        | Cycle power. If condition persists, replace the module. Call your local distributor or Spectrum Controls for assistance. |

## Channel Diagnostics

When an input channel is enabled, the module performs a diagnostic check to see that the channel has been properly configured. In addition, the channel is tested on every scan for configuration errors, over-range and under-range, and open-circuit conditions.

### Invalid Channel Configuration Detection

Whenever a channel configuration word is improperly defined, the module reports an error. See table 5.3 for a description of module errors.

### Over- or Under-Range Detection

Whenever the data received at the channel word is out of the defined operating range, an over-range or under-range error is indicated in input data word 9. Possible causes of an out-of-range condition include:

- The temperature is too hot or too cold for the type of thermocouple or RTD being used.
- The wrong thermocouple or RTD is being used for the input type selected, or for the configuration that was programmed.
- The input device is faulty.
- The signal input from the input device is beyond the scaling range.

### Open-Circuit Detection

On every other module scan, the module performs an open-circuit test on all enabled channels. Whenever an open-circuit condition occurs, the open-circuit bit for that channel is set in input data word 8. Possible causes of an open circuit include:

- the input device is broken
- a wire is loose or cut
- the input device is not installed on the configured channel
- A thermocouple or RTD is installed incorrectly



Attention! When using a 4-wire RTD, an open circuit condition is detected only if the excitation or the return are broken.

---



Attention! Open circuit detection is not applicable to the +/- 10 Volt range.

---

### Non-critical vs. Critical Module Errors

Non-critical module errors are typically recoverable. Channel errors (over-range or under-range errors) are non-critical. Non-critical error conditions are indicated in the module input data table.

Critical module errors are conditions that may prevent normal or recoverable operation of the system. When these types of errors occur, the system typically leaves the run or program mode of operation until the error can be dealt with. Critical module errors are indicated in Table 5.3 Extended Error Codes.

## Module Error Definition Table

Analog module errors are expressed in two fields as four-digit Hex format with the most significant digit as “don’t care” and irrelevant. The two fields are “Module Error” and “Extended Error Information”. The structure of the module error data is shown below.

**Table 5.1 Module Error Table**

| "Don't Care" Bits |    |    |    | Module Error |    |   | Extended Error Information |   |   |   |             |   |   |   |   |
|-------------------|----|----|----|--------------|----|---|----------------------------|---|---|---|-------------|---|---|---|---|
| 15                | 14 | 13 | 12 | 11           | 10 | 9 | 8                          | 7 | 6 | 5 | 4           | 3 | 2 | 1 | 0 |
| 0                 | 0  | 0  | 0  | 0            | 0  | 0 | 0                          | 0 | 0 | 0 | 0           | 0 | 0 | 0 | 0 |
| Hex Digit 4       |    |    |    | Hex Digit 3  |    |   | Hex Digit 2                |   |   |   | Hex Digit 1 |   |   |   |   |

### Module Error Field

The purpose of the module error field is to classify module errors into three distinct groups, as described in the table below. The type of error determines what kind of information exists in the extended error information field. These types of module errors are typically reported in the controller’s I/O status file. Refer to your controller manual for details.

**Table 5.2 Module Error Types**

| Error Type           | Module Error Field Value Bits 11 through 9 (binary) | Description  |
|----------------------|---|--|
| No errors            | 000   | No error is present. The extended error field holds no additional information.   |
| Hardware Errors      | 001   | General and specific hardware error codes are specified in the extended error information field.   |
| Configuration Errors | 010   | Module-specific error codes are indicated in the extended error field. These error codes correspond to options that you can change directly. For example, the input range or input filter selection. |

### Extended Error Information Field

Check the extended error information field when a non-zero value is present in the module error field. Depending upon the value in the module

error field, the extended error information field can contain error codes that are module-specific or common to all 1769 analog modules.

**NOTE** If no errors are present in the module error field, the extended error information field is set to zero.

#### *Hardware Errors*

General or module-specific hardware errors are indicated by module error code 001. See Table 5.3 Extended Error Codes.

#### *Configuration Errors*

If you set the fields in the configuration file to invalid or unsupported values, the module generates a critical error.

Table 5.3 Extended Error Codes lists the possible module-specific configuration error codes defined for the modules.

## Error Codes

The table below explains the extended error code.

**Table 5.3 Extended Error Codes**

| Error Type                          | Hex Equivalent | Module Error Code | Extended Error Information Code                          | Error Description  |
|-------------------------------------|----------------|-------------------|--|--|
| No error                            | X000           | 000               | 0 0000 0000  | No error   |
| Hardware-Specific Error             | X216           | 001               | 1 0001 0110  | Watchdog reset error                                     |
|                                     | X220           | 001               | 1 0010 0000  | Critical code failure                                    |
|                                     | X221           | 001               | 1 0010 0001  | Failed calibration/critical EEPROM failure               |
|                                     | X300           | 001               | 1 0000 0000  | Bad ADC  |
|                                     | X301           | 001               | 1 0000 0001  | Bad Power Supply Clock                                   |
| Module-Specific Configuration Error | X403           | 001               | 0 0000 0011  | Bad module configuration                                 |
|                                     | X404           | 001               | 0 0000 0100  | Channel 0 bad filter configuration                       |
|                                     | X405           | 001               | 0 0000 0101  | Channel 1 bad filter configuration                       |
|                                     | X406           | 001               | 0 0000 0110  | Channel 2 bad filter configuration                       |
|                                     | X407           | 001               | 0 0000 0111  | Channel 3 bad filter configuration                       |
|                                     | X408           | 001               | 0 0000 1000  | Channel 4 bad filter configuration                       |
|                                     | X409           | 001               | 0 0000 1001  | Channel 5 bad filter configuration                       |
|                                     | X40A           | 001               | 0 0000 1010  | Channel 6 bad filter configuration                       |
|                                     | X40B           | 001               | 0 0000 1011  | Channel 7 bad filter configuration                       |
|                                     | X40C           | 001               | 0 0000 1100  | Channel 0 bad data format                                |
|                                     | X40D           | 001               | 0 0000 1101  | Channel 1 bad data format                                |
|                                     | X40E           | 001               | 0 0000 1110  | Channel 2 bad data format                                |
|                                     | X40F           | 001               | 0 0000 1111  | Channel 3 bad data format                                |
|                                     | X410           | 001               | 0 0001 0000  | Channel 4 bad data format                                |
|                                     | X411           | 001               | 0 0001 0001  | Channel 5 bad data format                                |
|                                     | X412           | 001               | 0 0001 0010  | Channel 6 bad data format                                |
|                                     | X413           | 001               | 0 0001 0011  | Channel 7 bad data format                                |
|                                     | X414           | 001               | 0 0001 0100  | Channel 0 and 1 incorrect RTD channel pair configuration |
|                                     | X416           | 001               | 0 0001 0110  | Channel 2 and 3 incorrect RTD channel pair configuration |
|                                     | X418           | 001               | 0 0001 1000  | Channel 4 and 5 incorrect RTD channel pair configuration |
| X41A                                | 001            | 0 0001 1010       | Channel 6 and 7 incorrect RTD channel pair configuration |  |



## Module Inhibit Function

Some controllers support the module inhibit function. See your controller manual for details.

Whenever the 1769sc-IF8u module is inhibited, the module continues to provide information about changes at its inputs to the 1769 CompactBus master (for example, a CompactLogix controller).



# Appendix A

## 1769sc-IF8U Specifications

This appendix lists the specifications for the 1769sc-IF8U Analog Input module.

### Electrical Specifications 1769sc-IF8U

| Specification                    | Description   |
|----------------------------------|---|
| Configuration                    | 8 channels of thermocouple/voltage/current + 0 channels of RTD/Resistance inputs<br>6 channels of thermocouple/voltage/current + 1 channels of RTD/Resistance inputs<br>4 channels of thermocouple/voltage/current + 2 channels of RTD/Resistance inputs<br>2 channels of thermocouple/voltage/current + 3 channels of RTD/Resistance inputs<br>0 channels of thermocouple/voltage/current + 4 channels of RTD/Resistance inputs<br>Analog Multiplexed into one ADC   |
| Input Modes                      | Temperature, voltage, current, RTD, resistance  |
| Input Types                      | Thermocouple types J, K, T, E, R, S, B, N and C.<br>Voltage types +/-50 mV, +/-100 mV, 0-5 V, 1-5 V, 0-10 V, and +/-10 V<br>Current types 0-20 mA, 4-20 mA<br>RTD types Pt 385, Pt 3916, Ni 618, Ni 672, Cu 427<br>Resistance types 0-150 ohms, 0-1000 ohms, 0-3000 ohms  |
| Fault detection                  | Open circuit detection, over-range and under-range error bits.<br>Open circuit detection time is equal to the channel update time.  |
| CMRR                             | 115 dB minimum at 50 Hz<br>115 dB minimum at 60 Hz  |
| NMRR                             | 85 dB minimum at 50 Hz<br>85 dB minimum at 60 Hz  |
| Input Impedance                  | > 10M ohms for voltage, thermocouple, RTD, resistance inputs<br>250 ohms for current inputs   |
| Common Mode Voltage              | +/- 10V   |
| <b>Calibrated Accuracy</b>       | Linearization per ITS-90  |
| Thermocouple Inputs <sup>1</sup> | System accuracy at 25°C (10, 50, and 60 Hz filters):<br>Type J: +/- 0.6 degrees C<br>Type N (-210°C to -200°C): +/- 1.2 degrees C<br>(-200°C to 1300°C): +/- 1 degrees C<br>Type T (-270°C to -230°C): +/- 5.4 degrees C<br>(-230°C to 400°C): +/- 1 degrees C<br>Type K (-270°C to -225°C): +/- 7.5 degrees C<br>(-225°C to 1370°C): +/- 1 degrees C<br>Type E (-270°C to -210°C): +/- 4.2 degrees C<br>(-210°C to 1000°C): +/- 0.5 degrees C<br>Type C: +/- 1.8 degrees C<br>Type B: +/- 3.0 degrees C<br>Type S and R: +/- 1.7 degrees C<br><br>System accuracy at 0-60°C (10, 50, and 60 Hz filters):<br>Type J: +/- 0.9 degrees C<br>Type N (-210°C to -200°C): +/- 1.8 degrees C<br>(-200°C to 1300°C): +/- 1.5 degrees C<br>Type T (-270°C to -230°C): +/- 7.0 degrees C<br>(-230°C to 400°C): +/- 1.5 degrees C<br>Type K (-270°C to -225°C): +/- 10 degrees C<br>(-225°C to 1370°C): +/- 1.5 degrees C<br>Type E (-270°C to -210°C): +/- 6.3 degrees C<br>(-210°C to 1000°C): +/- 0.8 degrees C<br>Type C: +/- 3.5 degrees C<br>Type B: +/- 4.5 degrees C<br>Type S and R: +/- 2.6 degrees C |
| CJC accuracy <sup>2</sup>        | +/- 3.0 degrees C maximum   |
| CJC Sensor accuracy              | +/- 0.1 degrees C maximum   |

|   |  |
|---|--|
| Voltage Inputs                          | <p>System accuracy at 25°C (10, 50, and 60 Hz filters):</p> <ul style="list-style-type: none"> <li>+/- 15 uV maximum for +/- 50 mV inputs @ 25°C for 10 Hz, 50 Hz and 60 Hz filters.</li> <li>+/- 20 uV maximum for +/- 100 mV inputs @ 25°C for 10 Hz, 50 Hz and 60 Hz filters.</li> <li>+/- 2.5 mV maximum for 0-5V inputs @ 25°C for 10 Hz, 50 Hz and 60 Hz filters.</li> <li>+/- 2 mV maximum for 1-5V inputs @ 25°C for 10 Hz, 50 Hz and 60 Hz filters.</li> <li>+/- 5 mV maximum for 0-10V inputs @ 25°C for 10 Hz, 50 Hz and 60 Hz filters.</li> <li>+/- 10 mV maximum for +/-10V inputs @ 25°C for 10 Hz, 50 Hz and 60 Hz filters.</li> </ul> <p>System accuracy at 0-60°C (10, 50, and 60 Hz filters):</p> <ul style="list-style-type: none"> <li>+/- 25 uV maximum for +/- 50 mV inputs @ 0 – 60°C for 10 Hz, 50 Hz and 60 Hz filters.</li> <li>+/- 30 uV maximum for +/- 100 mV inputs @ 0 – 60°C for 10 Hz, 50 Hz and 60 Hz filters.</li> <li>+/- 5 mV maximum for 0-5V inputs @ 0 – 60°C for 10 Hz, 50 Hz and 60 Hz filters.</li> <li>+/- 4 mV maximum for 1-5V inputs @ 0 – 60°C for 10 Hz, 50 Hz and 60 Hz filters.</li> <li>+/- 10 mV maximum for 0-10V inputs @ 0 – 60°C for 10 Hz, 50 Hz and 60 Hz filters.</li> <li>+/- 20 mV maximum for +/-10V inputs @ 0 – 60°C for 10 Hz, 50 Hz and 60 Hz filters.</li> </ul> |
| Current Inputs                          | <p>System accuracy at 25°C (10, 50, and 60 Hz filters):</p> <ul style="list-style-type: none"> <li>+/- 20 uA maximum for 0-20 mA inputs @ 25°C for 10 Hz, 50 Hz and 60 Hz filters.</li> <li>+/- 16 uA maximum for 4-20 mA inputs @ 25°C for 10 Hz, 50 Hz and 60 Hz filters.</li> </ul> <p>System accuracy at 0-60°C (10, 50, and 60 Hz filters):</p> <ul style="list-style-type: none"> <li>+/- 50 uA maximum for 0-20 mA inputs @ 0-60°C for 10 Hz, 50 Hz and 60 Hz filters.</li> <li>+/- 40 uA maximum for 4-20 mA inputs @ 0-60°C for 10 Hz, 50 Hz and 60 Hz filters.</li> </ul>  |
| RTD Inputs                              | <p>System accuracy at 25°C (10, 50, and 60 Hz filters):</p> <ul style="list-style-type: none"> <li>+/- 0.91°C for Platinum 385</li> <li>+/- 0.5°C for Platinum 3916</li> <li>+/- 0.6°C for Nickel</li> <li>+/- 0.3°C for Nickel-Iron</li> <li>+/- 1.1°C for Copper</li> </ul> <p>System accuracy at 0-60°C (10, 50, and 60 Hz filters):</p> <ul style="list-style-type: none"> <li>+/- 1.4°C for Platinum 385</li> <li>+/- 0.8°C for Platinum 3916</li> <li>+/- 0.8°C for Nickel</li> <li>+/- 0.5°C for Nickel-Iron</li> <li>+/- 2.1°C for Copper</li> </ul>   |
| Resistance Inputs                       | <p>System accuracy at 25°C (10, 50, and 60 Hz filters):</p> <ul style="list-style-type: none"> <li>+/- 0.15 ohms for 150 ohm range</li> <li>+/- 1.0 ohms for 1000 ohm range</li> <li>+/- 1.5 ohms for 3000 ohm range</li> </ul> <p>System accuracy at 0-60°C (10, 50, and 60 Hz filters):</p> <ul style="list-style-type: none"> <li>+/- 0.25 ohms for 150 ohm range</li> <li>+/- 1.0 ohms for 1000 ohm range</li> <li>+/- 2.5 ohms for 3000 ohm range</li> </ul> <p>Note: Accuracy is dependent on the ADC output rate selection, data format, and input noise.</p>   |
| <b>Repeatability (at 25°C)</b>          | 10 Hz filter   |
| Thermocouple Types J and N              | +/- 0.1 °C   |
| Thermocouple Types N (-110°C to 1300°C) | +/- 0.1 °C   |
| Thermocouple Types N (-210°C to -110°C) | +/- 0.25 °C  |
| Thermocouple Types T (-170°C to 400°C)  | +/- 0.1 °C   |
| Thermocouple Types T (-270°C to -170°C) | +/- 1.5 °C   |
| Thermocouple Type K (-170°C to 1370°C)  | +/- 0.1 °C   |
| Thermocouple Type K (-270°C to -170°C)  | +/- 2.0 °C   |
| Thermocouple Type E (-220°C to 1000°C)  | +/- 0.1 °C   |
| Thermocouple Type E (-270°C to -220°C)  | +/- 1.0 °C   |
| Thermocouple Types S and R              | +/- 0.4 °C   |

|                                      |  |
|--------------------------------------|--|
| Thermocouple Type B                  | +/- 0.7 °C   |
| Thermocouple Type C                  | +/- 0.2 °C   |
| Millivolt Inputs                     | +/- 3 uV   |
| Voltage Inputs                       | +/- 150 mV   |
| Current Inputs                       | +/- 0.3 uA   |
| RTD/Resistance                       |  |
| Platinum 385                         | +/- 0.02 °C  |
| Platinum 3916                        | +/- 0.02 °C  |
| Copper                               | +/- 0.1 °C   |
| Nickel                               | +/- 0.01 °C  |
| Nickel-Iron                          | +/- 0.01 °C  |
| 0-150 ohm                            | +/- 5 mΩ   |
| 0-1000 ohm                           | +/- 15 mΩ  |
| 0-3000 ohm                           | +/- 50 mΩ  |
|                                      |  |
| Temp. Coefficient                    | Temperature compensation done by periodic calibration.   |
|                                      |  |
| Data formats                         | Eng units, Eng units X10, Scaled for PID, Prop. Counts, Percent of Full Scale  |
| Input Filter                         | 10 Hz, 50 Hz, 60 Hz, 250 Hz, 500 Hz, 1kHz  |
|                                      |  |
| <b>Channel Update Time</b>           |  |
| Single Channel Min                   | Voltage/Current/RTD/Resistance input: 7 ms with 1 kHz filter, no cal<br>Thermocouple input: 14 ms with 1 kHz filter, no cal                      |
| Single Channel Max                   | Voltage/Current/RTD/Resistance input: 303 ms with 10 Hz filter, no cal<br>Thermocouple input: 606 ms with 10 Hz filter, no cal                   |
| 8 Channel Min                        | Voltage/Current/RTD/Resistance inputs only: 56 ms with 1 kHz filter, no cal<br>Thermocouple or mixed inputs: 63 ms with 1 kHz filter, no cal     |
| 8 Channel Max                        | Voltage/Current/RTD/Resistance inputs only: 2424 ms with 10 Hz filter, no cal<br>Thermocouple or mixed inputs: 2727 ms with 10 Hz filter, no cal |
|                                      |  |
| <b>Open Circuit Detection Time</b>   | 7 ms – 2.1 seconds*<br>*Open circuit detection time is equal to the channel update time  |
|                                      |  |
| <b>Input Over-voltage Protection</b> | +/- 30 VDC Continuous  |
|                                      |  |
| <b>Input Over-Current Protection</b> | +/- 28 mA DC Continuous  |
|                                      |  |
| <b>Isolation</b>                     |  |
| Channel to Rack                      | 707 VDC for 1 minute    Optical & magnetic   |
| Channel to Channel                   | +/-10V   |
|                                      |  |
| Cable Impedance                      | 25 ohms maximum for specified accuracy.  |
|                                      |  |
| Input Protection                     | Voltage Mode +/- 30VDC continuous<br>Max Current input is limited due to input impedance (28mA max)  |
|                                      |  |
| <b>Power Requirements</b>            |  |
| Internal rack +5V                    | 150 mA maximum   |
| Internal rack +24V                   | 45 mA maximum  |
|                                      |  |
| Fusing                               | None   |

<sup>1</sup> These accuracies were measured without CJC compensation.

<sup>2</sup> To determine the overall accuracy, you must add the CJC accuracy to each thermocouple type. For example, if you are using a J thermocouple you would need to add ±3 degrees C, which calculates to ±3.6 degrees C overall. To improve accuracy, use a remote terminal block configuration. For more details refer to chapter 2.

## Environmental Conditions

| Mechanical                    | Standard                          | Class/Limit   |
|-------------------------------|-----------------------------------|---|
| <b>Vibration/Shock Unpack</b> |                                   |   |
| Shock & Vibration (op)        | IEC 68-2-6 FC<br>ICCG-ES #001 A.  | Class III   |
| Free Fall Unpackaged (non-op) | IEC 68-2-32#1                     |   |
| Shock Unpackaged (op)         | IEC 68-2-27Ea<br>ICCG-ES #002 A.  | Class III, Cat. I                                       |
| <b>Packaging Tests</b>        |                                   |   |
|                               | NSTA                              |   |
| <b>Temperature</b>            |                                   |   |
| Temp Cycle (op)               | IEC 68-2-14Nb<br>ICCG-ES #006 C.  | <b>0 to 60 Degree C</b><br>0 to +60 2 cycles .5hr/cycle |
| Thermal mapping of hot comp   |                                   | Done at 60 deg C, full load                             |
| <b>Storage Temperature</b>    |                                   |   |
| High temp (non-op)            | IEC 68-2-2Bb<br>ICCG-ES #006 C.   | <b>-40 to 85 Degree C</b><br>+85 for 16hrs              |
| Low temp (non-op)             | IEC 68-2-2Ab<br>ICCG-ES #006 C.   | -40 for 16hrs   |
| Temp Cycle (non-op)           | IEC 68-2-14Na<br>ICCG-ES #006 C.  | -40 to +85 2 cycles .5hr/cycle                          |
| <b>Humidity/Pressure</b>      |                                   |   |
| (non op)                      | IEC 68-2-30 Db                    | <b>5 to 95% RH (non cond.)</b><br>5 deg 95% 24hrs       |
| (op)                          | IEC 68-2-30 Db<br>ICCG-ES #008 B. | 5 deg 95% 24hrs   |

## Regulatory Compliance

UL 508  
 CSA (Class 1, Div 2, Group A,B,C,D)  
 CE compliance to EN 61010-1 and EN 61131-2  
 EN60079-0, EN60079-15 ATEX  
 ANSI/ISA 12.12.01

EX nA IIC T5 Gc

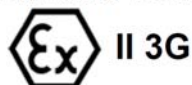

0C < Ta < 60C

DEMKO 11 ATEX 1103437x

### ATEX Special Conditions for Safe Use

- Provisions shall be made to prevent the rated voltage being exceeded by the transient disturbances of more than 40%.
- The system shall be mounted in an ATEX certified enclosure with a minimum ingress protection rating of at least IP54 as defined in IEC60529 or EN60529 and used in an environment of not more than pollution degree 2.

# Appendix B

## Two's Complement Binary Numbers

The processor memory stores 16-bit binary numbers. Two's complement binary is used when performing mathematical calculations internal to the processor. Analog input values from the analog modules are returned to the processor in 16-bit two's complement binary format. For positive numbers, the binary notation and two's complement binary notation are identical.

As indicated in the figure on the next page, each position in the number has a decimal value, beginning at the right with 20 and ending at the left with 215. Each position can be 0 or 1 in the processor memory. A 0 indicates a value of 0; a 1 indicates the decimal value of the position. The equivalent decimal value of the binary number is the sum of the position values.

### Positive Decimal Values

The far left position is always 0 for positive values. As indicated in the figure below, this limits the maximum positive decimal value to 32767 (all positions are 1 except the far left position). For example:

$$0000\ 1001\ 0000\ 1110 = 2^{11} + 2^8 + 2^3 + 2^2 + 2^1 = 2048 + 256 + 8 + 4 + 2 = 2318$$

$$0010\ 0011\ 0010\ 1000 = 2^{13} + 2^9 + 2^8 + 2^5 + 2^3 = 8192 + 512 + 256 + 32 + 8 = 9000$$

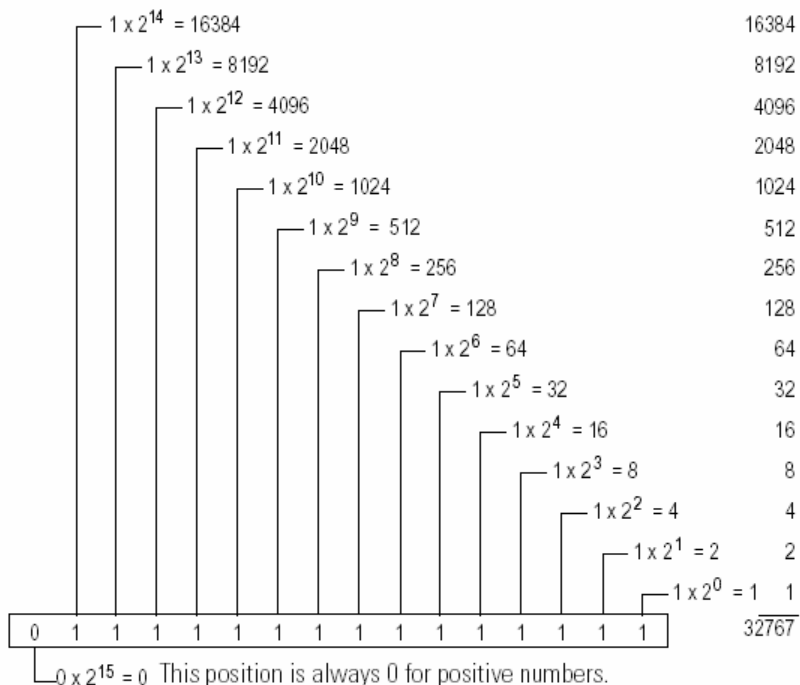

## Negative Decimal Values

In two's complement notation, the far left position is always 1 for negative values. The equivalent decimal value of the binary number is obtained by subtracting the value of the far left position, 32768, from the sum of the values of the other positions. In the figure below (all positions are 1), the value is  $32767 - 32768 = -1$ . For example:

$$1111\ 1000\ 0010\ 0011 = (2^{14} + 2^{13} + 2^{12} + 2^{11} + 2^5 + 2^1 + 2^0) - 2^{15} =$$

$$(16384 + 8192 + 4096 + 2048 + 32 + 2 + 1) - 32768 = 30755 - 32768 = -2013$$

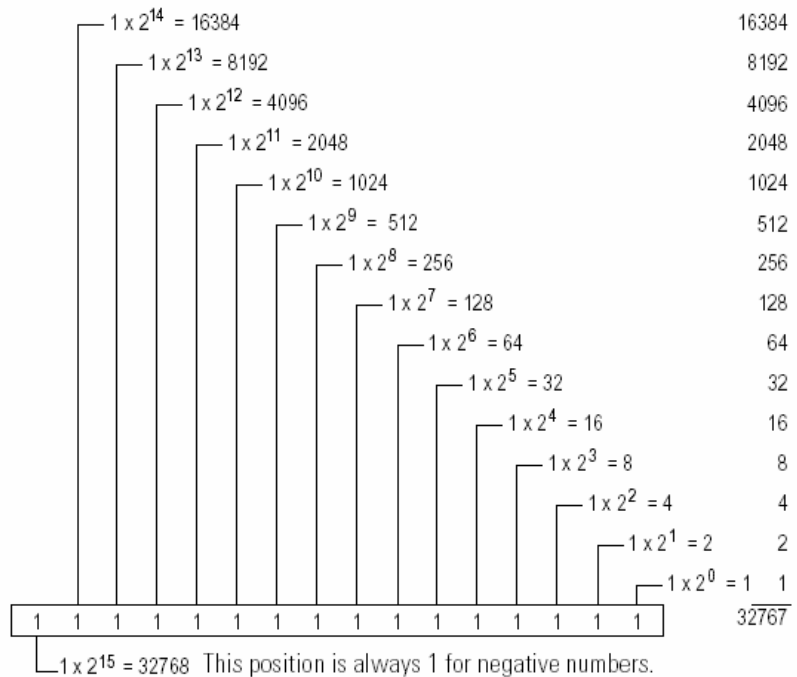







# Appendix C

## Thermocouple Descriptions

The information in this appendix was extracted from the NIST Monograph 175 issued in January 1990, which supersedes the IPTS-68 Monograph 125 issued in March 1974. NIST Monograph 175 is provided by the United States Department of Commerce, National Institute of Standards and Technology.

### International Temperature Scale of 1990

The ITS-90 [1,3] is realized, maintained, and disseminated by NIST to provide a standard scale of temperature for use in science and industry in the United States. This scale was adopted by the International Committee of Weights and Measures (CIPM) at its meeting in September 1989, and it became the official international temperature scale on January 1, 1990. The ITS-90 supersedes the IPTS-68(75) [2] and the 1976 Provisional 0.5 K to 30 K Temperature Scale (EPT-76) [4].

The adoption of the ITS-90 removed several deficiencies and limitations associated with IPTS-68. Temperatures on the ITS-90 are in closer agreement with thermodynamic values than were those of the IPTS-68 and EPT-76. Additionally, improvements have been made in the non-uniqueness and reproducibility of the temperature scale, especially in the temperature range from  $t_{68} = 630.74^{\circ}\text{C}$  to  $1064.43^{\circ}\text{C}$ , where the type S thermocouple was the standard interpolating device on the IPTS-68.

For additional technical information regarding ITS-90, refer to the NIST Monograph 175.

### Type B Thermocouples

This section discusses Platinum-30 percent Rhodium Alloy Versus Platinum-6 percent Rhodium Alloy thermocouples, commonly called type B thermocouples. This type is sometimes referred to by the nominal chemical composition of its thermoelements: platinum - 30 percent rhodium versus platinum - 6 percent rhodium or "30-6". The positive (BP) thermoelement typically contains  $29.60 \pm 0.2$  percent rhodium and the negative (BN) thermoelement usually contains  $6.12 \pm 0.02$  percent rhodium. The effect of differences in rhodium content are described later in this section. An industrial consensus standard [21] (ASTM E1159-87) specifies that rhodium having a purity of 99.98 percent shall be alloyed with platinum of 99.99 percent purity to produce the thermoelements. This consensus standard [21] describes the purity of commercial type B materials that are used in many industrial thermometry applications that meet the calibration tolerances described later in this section. Both

thermoelements will typically have significant impurities of elements such as palladium, iridium, iron, and silicon [38].

Studies by Ehringer [39], Walker et al. [25,26], and Glawe and Szaniszlo [24] have demonstrated that thermocouples, in which both legs are platinum-rhodium alloys, are suitable for reliable temperature measurements at high temperatures. Such thermocouples have been shown to offer the following distinct advantages over types R and S thermocouples at high temperatures: (1) improved stability, (2) increased mechanical strength, and (3) higher operating temperatures.

The research by Burns and Gallagher [38] indicated that the 30-6 thermocouple can be used intermittently (for several hours) up to 1790°C and continuously (for several hundred hours) at temperatures up to about 1700°C with only small changes in calibration. The maximum temperature limit for the thermocouple is governed, primarily, by the melting point of the Pt-6 percent rhodium thermoelement which is estimated to be about 1820°C by Acken [40]. The thermocouple is most reliable when used in a clean oxidizing atmosphere (air) but also has been used successfully in neutral atmospheres or vacuum by Walker et al [25,26], Hendricks and McElroy [41], and Glawe and Szaniszlo [24]. The stability of the thermocouple at high temperatures has been shown by Walker et al. [25,26] to depend, primarily, on the quality of the materials used for protecting and insulating the thermocouple. High purity alumina with low iron-content appears to be the most suitable material for the purpose. Type B thermocouples should not be used in reducing atmospheres, nor those containing deleterious vapors or other contaminants that are reactive with the platinum group metals [42], unless suitably protected with nonmetallic protecting tubes. They should never be used in metallic protecting tubes at high temperatures.

The Seebeck coefficient of type B thermocouples decreases with decreasing temperature below about 1600°C and becomes almost negligible at room temperature. Consequently, in most applications the reference junction temperature of the thermocouple does not need to be controlled or even known, as long as it is between 0°C and 50°C. For example, the voltage developed by the thermocouple, with the reference junction at 0°C, undergoes a reversal in sign at about 42°C, and between 0°C and 50°C varies from a minimum of -2.6µV near 21°C to a maximum of 2.3µV at 50°C. Therefore, in use, if the reference junction of the thermocouple is within the range 0°C to 50°C, then a 0°C reference junction temperature can be assumed and the error introduced will not exceed 3µV. At temperatures above 1100°C, an additional measurement error of 3µV (about 0.3°C) would be insignificant in most instances.

ASTM Standard E230-87 in the 1992 Annual Book of ASTM Standards [7] specifies that the initial calibration tolerances for type B commercial thermocouples be ±0.5 percent between 870°C and 1700°C. Type B thermocouples can also be supplied to meet special tolerances of ±0.25

percent. Tolerances are not specified for type B thermocouples below 870°C.

The suggested upper temperature limit of 1700°C given in the ASTM standard [7] for protected type B thermocouples applies to AWG 24 (0.51 mm) wire. This temperature limit applies to thermocouples used in conventional closed-end protecting tubes and it is intended only as a rough guide to the user. It does not apply to thermocouples having compacted mineral oxide insulation.

## Type E Thermocouples

This section describes Nickel-Chromium Alloy Versus Copper-Nickel Alloy thermocouples, known as type E thermocouples. This type, and the other base-metal types, do not have specific chemical compositions given in standards; rather, any materials whose emf-temperature relationship agrees with that of the specified reference table within certain tolerances can be considered to be a type E thermocouple. The positive thermoelement, EP, is the same material as KP. The negative thermoelement, EN, is the same material as TN.

The low-temperature research [8] by members of the NBS Cryogenics Division showed that type E thermocouples are very useful down to liquid hydrogen temperatures (n.b.p. about 20.3K) where their Seebeck coefficient is about 8mV/°C. They may even be used down to liquid helium temperatures (4.2°K) although their Seebeck coefficient becomes quite low, only about 2mV/°C at 4K. Both thermoelements of type E thermocouples have a relatively low thermal conductivity, good resistance to corrosion in moist atmospheres, and reasonably good homogeneity. For these three reasons and their relatively high Seebeck coefficients, type E thermocouples have been recommended [8] as the most useful of the letter-designated thermocouple types for low-temperature measurements.

For measurements below 20K, the non-letter-designated thermocouple, KP versus gold-0.07, is recommended. The properties of this thermocouple have been described by Sparks and Powell [12].

Type E thermocouples also have the largest Seebeck coefficient above 0°C for any of the letter-designated thermocouples. For that reason they are being used more often whenever environmental conditions permit.

Type E thermocouples are recommended by the ASTM [5] for use in the temperature range from -200°C to 900°C in oxidizing or inert atmospheres. If used for extended times in air above 500°C, heavy gauge wires are recommended because the oxidation rate is rapid at elevated temperatures. About 50 years ago, Dahl [11] studied the thermoelectric stability of EP and EN type alloys when heated in air at elevated temperatures. His work should be consulted for details. More recent stability data on these alloys in air were reported by Burley et al. [13]. Type E thermocouples should not be used at high temperatures in

sulfurous, reducing, or alternately reducing and oxidizing atmospheres unless suitably protected with protecting tubes. They also should not be used in vacuum (at high temperatures) for extended times because the chromium in the positive thermoelement, a nickel-chromium alloy, vaporizes out of solution and alters the calibration. In addition, their use in atmospheres that promote “green-rot” corrosion of the positive thermoelement should be avoided. Such corrosion results from the preferential oxidation of chromium in atmospheres with low, but not negligible, oxygen content and can lead to a large decrease in the thermoelectric voltage of the thermocouple with time. The effect is most serious at temperatures between 800°C and 1050°C.

The negative thermoelement, a copper-nickel alloy, is subject to composition changes under thermal neutron irradiation since the copper is converted to nickel and zinc.

Neither thermoelement of type E thermocouples is very sensitive to minor changes in composition or impurity level because both are already heavily alloyed. Similarly, they are also not extremely sensitive to minor differences in heat treatment (provided that the treatment does not violate any of the restrictions mentioned above). For most general applications, they may be used with the heat treatment given by the wire manufacturers. However, when the highest accuracy is sought, additional preparatory heat treatments may be desirable in order to enhance their performance. Details on this and other phases of the use and behavior of type KP thermoelements (EP is the same as KP) are given in publications by Pots and McElroy [14], by Burley and Ackland [15], by Burley [16], by Wang and Starr [17,18], by Bentley [19], and by Kollie et al. [20].

ASTM Standard E230-87 in the 1992 Annual Book of ASTM Standards [7] specifies that the initial calibration tolerances for type E commercial thermocouples be  $\pm 1.7^{\circ}\text{C}$  or  $\pm 0.5$  percent (whichever is greater) between  $0^{\circ}\text{C}$  and  $900^{\circ}\text{C}$ , and  $\pm 1.7^{\circ}\text{C}$  or  $\pm 1$  percent (whichever is greater) between  $-200^{\circ}\text{C}$  and  $0^{\circ}\text{C}$ . Type E thermocouples can also be supplied to meet special tolerances which are equal to  $\pm 1^{\circ}\text{C}$  or  $\pm 0.4$  percent (whichever is greater) between  $0^{\circ}\text{C}$  and  $900^{\circ}\text{C}$ , and  $\pm 1^{\circ}\text{C}$  or  $\pm 0.5$  percent (whichever is greater) between  $-200^{\circ}\text{C}$  and  $0^{\circ}\text{C}$ . Type E thermocouple materials are normally supplied to meet the tolerances specified for temperatures above  $0^{\circ}\text{C}$ . The same materials, however, may not satisfy the tolerances specified for the  $-200^{\circ}\text{C}$  to  $0^{\circ}\text{C}$  range. If materials are required to meet the tolerances below  $0^{\circ}\text{C}$ , this should be specified when they are purchased.

The suggested upper temperature limit,  $870^{\circ}\text{C}$ , given in the ASTM standard [7] for protected type E thermocouples applies to AWG 8 (3.25 mm) wire. It decreases to  $650^{\circ}\text{C}$  for AWG 14 (1.63 mm),  $540^{\circ}\text{C}$  for AWG 20 (0.81 mm),  $430^{\circ}\text{C}$  for AWG 24 or 28 (0.51 mm or 0.33 mm), and  $370^{\circ}\text{C}$  for AWG 30 (0.25 mm). These temperature limits apply to thermocouples used in conventional closed-end protecting tubes and they

are intended only as a rough guide to the user. They do not apply to thermocouples having compacted mineral oxide insulation.

## Type J Thermocouples

This section discusses Iron Versus Copper-Nickel Alloy (SAMA) thermocouples, called type J thermocouples. A type J thermocouple is one of the most common types of industrial thermocouples, because of its relatively high Seebeck coefficient and low cost. It has been reported that more than 200 tons of type J materials are supplied annually to industry in this country. However, this type is least suitable for accurate thermometry because there are significant nonlinear deviations in the thermoelectric output of thermocouples obtained from different manufacturers. These irregular deviations lead to difficulties in obtaining accurate calibrations based on a limited number of calibration points. The positive thermoelement is commercially pure (99.5 percent Fe) iron, usually containing significant impurity levels of carbon, chromium, copper, manganese, nickel, phosphorus, silicon, and sulfur. Thermocouple wire represents such a small fraction of the total production of commercial iron wire that the producers do not control the chemical composition to maintain constant thermoelectric properties. Instead, instrument companies and thermocouple fabricators select material most suitable for the thermocouple usage. The total and specific types of impurities that occur in commercial iron change with time, location of primary ores, and methods of smelting. Many unusual lots have been selected in the past, for example spools of industrial iron wire and even scrapped rails from an elevated train line. At present, iron wire that most closely fits these tables has about 0.25 percent manganese and 0.12 percent copper, plus other minor impurities.

The negative thermoelement for type J thermocouples is a copper-nickel alloy known ambiguously as constantan. The word constantan has commonly referred to copper-nickel alloys containing anywhere from 45 to 60 percent copper, plus minor impurities of carbon, cobalt, iron, and manganese. Constantan for type J thermocouples usually contains about 55 percent copper, 45 percent nickel, and a small but thermoelectrically significant amount of cobalt, iron, and manganese, about 0.1 percent or more. It should be emphasized that type JN thermoelements are NOT generally interchangeable with type TN (or EN) thermoelements, although they are all referred to as “constantan”. In order to provide some differentiation in nomenclature, type JN is often referred to as SAMA constantan.

Type J thermocouples are recommended by the ASTM [5] for use in the temperature range from 0°C to 760°C in vacuum, oxidizing, reducing, or inert atmospheres. If used for extended times in air above 500°C, heavy gauge wires are recommended because the oxidation rate is rapid at elevated temperatures. Oxidation normally causes a gradual decrease in the thermoelectric voltage of the thermocouple with time. Because iron

rusts in moist atmospheres and may become brittle, type J thermocouples are not recommended for use below 0°C. In addition, they should not be used unprotected in sulfurous atmospheres above 500°C.

The positive thermoelement, iron, is relatively insensitive to composition changes under thermal neutron irradiation, but does exhibit a slight increase in manganese content. The negative thermoelement, a copper-nickel alloy, is subject to substantial composition changes under thermal neutron irradiation since copper is converted to nickel and zinc.

Iron undergoes a magnetic transformation near 769°C and an alpha-gamma crystal transformation near 910°C [6]. Both of these transformations, especially the latter, seriously affect the thermoelectric properties of iron, and therefore of type J thermocouples. This behavior and the rapid oxidation rate of iron are the main reasons why iron versus constantan thermocouples are not recommended as a standardized type above 760°C. If type J thermocouples are taken to high temperatures, especially above 900°C, they will lose the accuracy of their calibration when they are recycled to lower temperatures. If type J thermocouples are used in air at temperatures above 760°C, only the largest wire, AWG 8 (3.3 mm) should be used and they should be held at the measured temperature for 10 to 20 minutes before readings are taken. The thermoelectric voltage of the type J thermocouples may change by as much as 40mV (or 0.6°C equivalent) per minute when first brought up to temperatures near 900°C.

ASTM Standard E230-87 in the 1992 Annual Book of ASTM Standards [7] specifies that the initial calibration tolerances for type J commercial thermocouples be  $\pm 2.2^\circ\text{C}$  or  $\pm 0.75$  percent (whichever is greater) between 0°C and 750°C. Type J thermocouples can also be supplied to meet special tolerances, which are equal to approximately one-half the standard tolerances given above. Tolerances are not specified for type J thermocouples below 0°C or above 750°C.

The suggested upper temperature limit of 760°C given in the above ASTM standard [7] for protected type J thermocouples applies to AWG 8 (3.25 mm) wire. For smaller diameter wires the suggested upper temperature limit decreases to 590°C for AWG 14 (1.63 mm), 480°C for AWG 20 (0.81 mm), 370°C for AWG 24 or 28 (0.51 mm or 0.33 mm), and 320°C for AWG 30 (0.25 mm). These temperature limits apply to thermocouples used in conventional closed-end protecting tubes and they are intended only as a rough guide to the user. They do not apply to sheathed thermocouples having compacted mineral oxide insulation.

## Type K Thermocouples

This section describes Nickel-Chromium Alloy Versus Nickel-Aluminum Alloy thermocouples, called type K thermocouples. This type is more resistant to oxidation at elevated temperatures than types E, J, or T thermocouples and, consequently, it finds wide application at temperatures



above 500°C. The positive thermoelement, KP, which is the same as EP, is an alloy that typically contains about 89 to 90 percent nickel, 9 to about 9.5 percent chromium, both silicon and iron in amounts up to about 0.5 percent, plus smaller amounts of other constituents such as carbon, manganese, cobalt, and niobium. The negative thermoelement, KN, is typically composed of about 95 to 96 percent nickel, 1 to 1.5 percent silicon, 1 to 2.3 percent aluminum, 1.6 to 3.2 percent manganese, up to about 0.5 percent cobalt and smaller amounts of other constituents such as iron, copper, and lead. Also, type KN thermoelements with modified compositions are available for use in special applications. These include alloys in which the manganese and aluminum contents are reduced or eliminated, while the silicon and cobalt contents are increased.

The low temperature research [8] by members of the NBS Cryogenics Division showed that the type K thermocouple may be used down to liquid helium temperatures (about 4K) but that its Seebeck coefficient becomes quite small below 20K. Its Seebeck coefficient at 20K is only about 4mV/K, being roughly one-half that of the type E thermocouple which is the most suitable of the letter-designated thermocouples types for measurements down to 20K. Type KP and type KN thermoelements do have a relatively low thermal conductivity and good resistance to corrosion in moist atmospheres at low temperatures. The thermoelectric homogeneity of type KN thermoelements, however, was found [8] to be not quite as good as that of type EN thermoelements.

Type K thermocouples are recommended by the ASTM [5] for use at temperatures within the range -250°C to 1260°C in oxidizing or inert atmospheres. Both the KP and the KN thermoelements are subject to deterioration by oxidation when used in air above about 750°C, but even so, type K thermocouples may be used at temperatures up to about 1350°C for short periods with only small changes in calibration. When oxidation occurs it normally leads to a gradual increase in the thermoelectric voltage with time. The magnitude of the change in the thermoelectric voltage and the physical life of the thermocouple will depend upon such factors as the temperature, the time at temperature, the diameter of the thermoelements and the conditions of use.

The ASTM Manual [5] indicates that type K thermocouples should not be used at high temperatures in sulfurous, reducing, or alternately oxidizing and reducing atmospheres unless suitably protected with protecting tubes. They also should not be used in vacuum (at high temperatures) for extended times because the chromium in the positive thermoelement, a nickel-chromium alloy, vaporizes out of solution and alters the calibration. In addition, avoid their use in atmospheres that promote “green-rot” corrosion [9] of the positive thermoelement. Such corrosion results from the preferential oxidation of chromium in atmospheres with low, but not negligible, oxygen content and can lead to a large decrease in the thermoelectric voltage of the thermocouple with time. The effect is most serious at temperatures between 800°C and 1050°C.

Both thermoelements of type K thermocouples are reasonably stable, thermoelectrically, under neutron irradiation since the resulting changes in their chemical compositions due to transmutation are small. The KN thermoelements are somewhat less stable than the KP thermoelements in that they experience a small increase in the iron content accompanied by a slight decrease in the manganese and cobalt contents.

ASTM Standard E230-87 in the 1992 Annual Book of ASTM Standards [7] specifies that the initial calibration tolerances for type K commercial thermocouples be  $\pm 2.2^{\circ}\text{C}$  or  $\pm 0.75$  percent (whichever is greater) between  $0^{\circ}\text{C}$  and  $1250^{\circ}\text{C}$ , and  $\pm 2.2^{\circ}\text{C}$  or  $\pm 2$  percent (whichever is greater) between  $-200^{\circ}\text{C}$  and  $0^{\circ}\text{C}$ . In the  $0^{\circ}\text{C}$  to  $1250^{\circ}\text{C}$  range, type K thermocouples can be supplied to meet special tolerances that are equal to approximately one-half the standard tolerances given above. Type K thermocouple materials are normally supplied to meet the tolerances specified for temperatures above  $0^{\circ}\text{C}$ . However, the same materials may not satisfy the tolerances specified for the  $-200^{\circ}\text{C}$  to  $0^{\circ}\text{C}$  range. If materials are required to meet the tolerances below  $0^{\circ}\text{C}$ , this should be specified when they are purchased.

The suggested upper temperature limit of  $1260^{\circ}\text{C}$  given in the ASTM standard [7] for protected type K thermocouples applies to AWG 8 (3.25 mm) wire. It decreases to  $1090^{\circ}\text{C}$  for AWG 14 (1.63 mm),  $980^{\circ}\text{C}$  for AWG 20 (0.81 mm),  $870$  for AWG 24 or 28 (0.51 mm or 0.33 mm), and  $760^{\circ}\text{C}$  for AWG 30 (0.25 mm). These temperature limits apply to thermocouples used in conventional closed-end protecting tubes and they are intended only as a rough guide to the user. They do not apply to thermocouples having compacted mineral oxide insulation.

## Type N Thermocouples

This section describes Nickel-Chromium-Silicon Alloy Versus Nickel-Silicon-Magnesium Alloy thermocouples, commonly referred to as type N thermocouples. This type is the newest of the letter-designated thermocouples. It offers higher thermoelectric stability in air above  $1000^{\circ}\text{C}$  and better air-oxidation resistance than types E, J, and K thermocouples. The positive thermoelement, NP, is an alloy that typically contains about 84 percent nickel, 14 to 14.4 percent chromium, 1.3 to 1.6 percent silicon, plus small amounts (usually not exceeding about 0.1 percent) of other elements such as magnesium, iron, carbon, and cobalt. The negative thermoelement, NN, is an alloy that typically contains about 95 percent nickel, 4.2 to 4.6 percent silicon, 0.5 to 1.5 percent magnesium, plus minor impurities of iron, cobalt, manganese and carbon totaling about 0.1 to 0.3 percent. The type NP and NN alloys were known originally [16] as nicrosil and nisil, respectively.

The research reported in NBS Monograph 161 showed that the type N thermocouple may be used down to liquid helium temperatures (about 4K) but that its Seebeck coefficient becomes very small below 20K. Its Seebeck coefficient at 20K is about  $2.5\text{mV/K}$ , roughly one-third that of

type E thermocouples which are the most suitable of the letter-designated thermocouples types for measurements down to 20K. Nevertheless, types NP and NN thermoelements do have a relatively low thermal conductivity and good resistance to corrosion in moist atmospheres at low temperatures.

Type N thermocouples are best suited for use in oxidizing or inert atmospheres. Their suggested upper temperature limit, when used in conventional closed-end protecting tubes, is set at 1260°C by the ASTM [7] for 3.25 mm diameter thermoelements. Their maximum upper temperature limit is defined by the melting temperature of the thermoelements, which are nominally 1410°C for type NP and 1340°C for type NN [5]. The thermoelectric stability and physical life of type N thermocouples when used in air at elevated temperatures will depend upon factors such as the temperature, the time at temperature, the diameter of the thermoelements, and the conditions of use. Their thermoelectric stability and oxidation resistance in air have been investigated and compared with those of type K thermocouples by Burley [16], by Burley and others [13,44-47], by Wang and Starr [17,43,48,49], by McLaren and Murdock [33], by Bentley [19], and by Hess [50].

Type N thermocouples, in general, are subject to the same environmental restrictions as types E and K. They are not recommended for use at high temperatures in sulfurous, reducing, or alternately oxidizing and reducing atmospheres unless suitably protected with protecting tubes. They also should not be used in vacuum (at high temperatures) for extended times because the chromium and silicon in the positive thermoelement, a nickel-chromium-silicon alloy, vaporize out of solution and alter the calibration. In addition, their use in atmospheres with low, but not negligible, oxygen content is not recommended, since it can lead to changes in calibration due to the preferential oxidation of chromium in the positive thermoelement. Nevertheless, Wang and Starr [49] studied the performances of type N thermocouples in reducing atmospheres, as well as in stagnant air, at temperatures in the 870°C to 1180°C range and found them to be markedly more stable thermoelectrically than type K thermocouples under similar conditions.

The performance of type N thermocouples fabricated in metal-sheathed, compacted ceramic insulated form also has been the subject of considerable study. Anderson and others [51], Bentley and Morgan [52], and Wang and Bediones [53] have evaluated the high-temperature, thermoelectric stability of thermocouples insulated with magnesium oxide and sheathed in Inconel and in stainless steel. Their studies showed that the thermoelectric instabilities of such assemblies increase rapidly with temperature above 1000°C. It was found also that the smaller the diameter of the sheath the greater the instability. Additionally, thermocouples sheathed in Inconel showed substantially less instability above 1000°C than those sheathed in stainless steel. Bentley and Morgan [52] stressed the importance of using Inconel sheathing with a very low

manganese content to achieve the most stable performance. The use of special Ni-Cr based alloys for sheathing to improve the chemical and physical compatibility with the thermoelements also has been investigated by Burley [54-56] and by Bentley [57-60].

Neither thermoelement of a type N thermocouple is extremely sensitive to minor differences in heat treatment (provided that the treatment does not violate any of the restrictions mentioned above). For most general applications, they may be used with the heat treatment routinely given by the wire manufacturer. Bentley [61,62], however, has reported reversible changes in the Seebeck coefficient of type NP and NN thermoelements when heated at temperatures between 200°C and 1000°C. These impose limitations on the accuracy obtainable with type N thermocouples. The magnitude of such changes was found to depend on the source of the thermoelements. Consequently, when the highest accuracy and stability are sought, selective testing of materials, as well as special preparatory heat treatments beyond those given by the manufacturer, will usually be necessary. Bentley's articles [61,62] should be consulted for guidelines and details.

ASTM Standard E230-87 in the 1992 Annual Book of ASTM Standards [7] specifies that the initial calibration tolerances for type N commercial thermocouples be  $\pm 2.2^\circ\text{C}$  or  $\pm 0.75$  percent (whichever is greater) between 0°C and 1250°C. Type N thermocouples can also be supplied to meet special tolerances that are equal to approximately one-half the standard tolerances given above. Tolerances are not specified for type N thermocouples below 0°C.

The suggested upper temperature limit of 1260°C given in the ASTM standard [7] for protected type N thermocouples applies to AWG 8 (3.25 mm) wire. It decreases to 1090°C for AWG 14 (1.63 mm), 980°C for AWG 20 (0.81 mm), 870°C for AWG 24 or 28 (0.51 mm or 0.33 mm), and 760°C for AWG 30 (0.25 mm). These temperature limits apply to thermocouples used in conventional closed-end protecting tubes and they are intended only as a rough guide to the user. They do not apply to thermocouples having compacted mineral oxide insulation.

## Type R Thermocouples

This section describes Platinum-13 percent Rhodium Alloy Versus Platinum thermocouples, called type R thermocouples. This type is often referred to by the nominal chemical composition of its positive (RP) thermoelement: platinum-13 percent rhodium. The negative (RN) thermoelement is commercially-available platinum that has a nominal purity of 99.99 percent [21]. An industrial consensus standard (ASTM E1159-87) specifies that rhodium having a nominal purity of 99.98 percent shall be alloyed with platinum of 99.99 percent purity to produce the positive thermoelement, which typically contains  $13.00 \pm 0.05$  percent rhodium by weight. This consensus standard [21] describes the purity of commercial type R materials that are used in many industrial thermometry

applications and that meet the calibration tolerances described later in this section. It does not cover, however, the higher-purity, reference-grade materials that traditionally were used to construct thermocouples used as transfer standards and reference thermometers in various laboratory applications and to develop reference functions and tables [22,23]. The higher purity alloy material typically contains less than 500 atomic ppm of impurities and the platinum less than 100 atomic ppm of impurities [22]. Differences between such high purity commercial material and the platinum thermoelectric reference standard, Pt-67, are described in [22] and [23].

A reference function for the type R thermocouple, based on the ITS-90 and the SI volt, was determined recently from new data obtained in a collaborative effort by NIST and NPL. The results of this international collaboration were reported by Burns et al [23]. The function was used to compute the reference table given in this monograph.

Type R thermocouples have about a 12 percent larger Seebeck coefficient than do Type S thermocouples over much of the range. Type R thermocouples were not standard interpolating instruments on the IPTS-68 for the 630.74°C to gold freezing-point range. Other than these two points, and remarks regarding history and composition, all of the precautions and restrictions on usage given in the section on type S thermocouples also apply to type R thermocouples. Glawe and Szaniszlo [24], and Walker et al [25,26] have determined the effects that prolonged exposure at elevated temperatures (>1200°C) in vacuum, air, and argon atmospheres have on the thermoelectric voltages of type R thermocouples.

ASTM Standard E230-87 in the 1992 Annual Book of ASTM Standards [7] specifies that the initial calibration tolerances for type R commercial thermocouples be  $\pm 1.5^{\circ}\text{C}$  or  $\pm 0.25$  percent (whichever is greater) between  $0^{\circ}\text{C}$  and  $1450^{\circ}\text{C}$ . Type R thermocouples can be supplied to meet special tolerances of  $\pm 0.6^{\circ}\text{C}$  or  $\pm 0.1$  percent (whichever is greater). The suggested upper temperature limit,  $1480^{\circ}\text{C}$ , given in the ASTM standard [7] for protected type R thermocouples applies to AWG 24 (0.51 mm) wire. This temperature limit applies to thermocouples used in conventional closed-end protecting tubes and it is intended only as a rough guide to the user. It does not apply to thermocouples having compacted mineral oxide insulation.

## Type S Thermocouples

This section describes Platinum-10 percent Rhodium Alloy Versus Platinum thermocouples, commonly known as type S thermocouples. This type is often referred to by the nominal chemical composition of its positive (SP) thermoelement: platinum-10 percent rhodium. The negative (SN) thermoelement is commercially available platinum that has a nominal purity of 99.99 percent [21]. An industrial consensus standard (ASTM E1159-87) specifies that rhodium having a nominal purity of 99.98 percent shall be alloyed with platinum of 99.99 percent purity to produce the

positive thermoelement, which typically contains  $10.00 \pm 0.05$  percent rhodium by weight. The consensus standard [21] describes the purity of commercial type S materials that are used in many industrial thermometry applications and that meet the calibration tolerances described later in this section. It does not cover, however, the higher-purity, reference-grade materials that traditionally were used to construct thermocouples used as standard instruments of the IPTS-68, as transfer standards and reference thermometers in various laboratory applications, and to develop reference functions and tables [27,28]. The higher purity alloy material typically contains less than 500 atomic ppm of impurities and the platinum less than 100 atomic ppm of impurities [27]. Difference between such high purity commercial material and the platinum thermoelectric reference standard, Pt-67, are described in [27] and [28].

A reference function for the type S thermocouple, based on the ITS-90 and the SI volt, was determined recently from new data obtained in an international collaborative effort involving eight national laboratories. The results of this international collaboration were reported by Burns et al. [28]. The new function was used to compute the reference table given in this monograph.

Research [27] demonstrated that type S thermocouples can be used from  $-50^{\circ}\text{C}$  to the platinum melting-point temperature. They may be used intermittently at temperatures up to the platinum melting point and continuously up to about  $1300^{\circ}\text{C}$  with only small changes in their calibrations. The ultimate useful life of the thermocouples when used at such elevated temperatures is governed primarily by physical problems of impurity diffusion and grain growth, which lead to mechanical failure. The thermocouple is most reliable when used in a clean oxidizing atmosphere (air) but may be used also in inert gaseous atmospheres or in a vacuum for short periods of time. However, type B thermocouples are generally more suitable for such applications above  $1200^{\circ}\text{C}$ . Type S thermocouples should not be used in reducing atmospheres, nor in those containing metallic vapor (such as lead or zinc), nonmetallic vapors (such as arsenic, phosphorus, or sulfur) or easily reduced oxides, unless they are suitably protected with nonmetallic protecting tubes. Also, they should never be inserted directly into a metallic protection tube for use at high temperatures. The stability of type S thermocouples at high temperatures ( $>1200^{\circ}\text{C}$ ) depends primarily upon the quality of the materials used for protection and insulation, and has been studied by Walker et al. [25,26] and by Bentley [29]. High purity alumina, with low iron content, appears to be the most suitable material for insulating, protecting, and mechanically supporting the thermocouple wires.

Both thermoelements of type S thermocouples are sensitive to impurity contamination. In fact, type R thermocouples were developed essentially because of iron contamination effects in some British platinum-10 percent rhodium wires. The effects of various impurities on the thermoelectric voltages of platinum based thermocouple materials have been described by Rhys and Taimsalu [35], by Cochrane [36] and by Aliotta [37]. Impurity



contamination usually causes negative changes [25,26,29] in the thermoelectric voltage of the thermocouple with time, the extent of which will depend upon the type and amount of chemical contaminant. Such changes were shown to be due mainly to the platinum thermoelement [25,26,29]. Volatilization of the rhodium from the positive thermoelement for the vapor transport of rhodium from the positive thermoelement to the pure platinum negative thermoelement also will cause negative drifts in the thermoelectric voltage. Bentley [29] demonstrated that the vapor transport of rhodium can be virtually eliminated at 1700°C by using a single length of twin-bore tubing to insulate the thermoelements and that contamination of the thermocouple by impurities transferred from the alumina insulator can be reduced by heat treating the insulator prior to its use.

McLaren and Murdock [30-33] and Bentley and Jones [34] thoroughly studied the performance of type S thermocouples in the range 0°C to 1100°C. They described how thermally reversible effects, such as quenched-in point defects, mechanical stresses, and preferential oxidation of rhodium in the type SP thermoelement, cause chemical and physical inhomogeneities in the thermocouple and thereby limit its accuracy in this range. They emphasized the importance of annealing techniques.

The positive thermoelement is unstable in a thermal neutron flux because the rhodium converts to palladium. The negative thermoelement is relatively stable to neutron transmutation. Fast neutron bombardment, however, will cause physical damage, which will change the thermoelectric voltage unless it is annealed out.

At the gold freezing-point temperature, 1064.18°C, the thermoelectric voltage of type S thermocouples increases by about 340µV (about 3 percent) per weight percent increase in rhodium content; the Seebeck coefficient increases by about 4 percent per weight percent increase at the same temperature.

ASTM Standard E230-87 in the 1992 Annual Book of ASTM Standards [7] specifies that the initial calibration tolerances for type S commercial thermocouples be  $\pm 1.5^\circ\text{C}$  or  $\pm 0.25$  percent (whichever is greater) between 0°C and 1450°C. Type S thermocouples can be supplied to meet special tolerances of  $\pm 0.6^\circ\text{C}$  or  $\pm 0.1$  percent (whichever is greater).

The suggested upper temperature limit, 1480°C, given in the ASTM standard [7] for protected type S thermocouples applies to AWG 24 (0.51 mm) wire. This temperature limit applies to thermocouples used in conventional closed-end protecting tubes and it is intended only as a rough guide to the user. It does not apply to thermocouples having compacted mineral oxide insulation.

## Type T Thermocouples

This section describes Copper Versus Copper-Nickel Alloy thermocouples, called type T thermocouples. This type is one of the oldest and most popular thermocouples for determining temperatures within the range from about 370°C down to the triple point of neon (-248.5939°C). Its positive thermoelement, TP, is typically copper of high electrical conductivity and low oxygen content that conforms to ASTM Specification B3 for soft or annealed bare copper wire. Such material is about 99.95 percent pure copper with an oxygen content varying from 0.02 to 0.07 percent (depending upon sulfur content) and with other impurities totaling about 0.01 percent. Above about -200°C, the thermoelectric properties of type TP thermoelements, which satisfy the above conditions, are exceptionally uniform and exhibit little variation between lots. Below about -200°C the thermoelectric properties are affected more strongly by the presence of dilute transition metal solutes, particularly iron.

The negative thermoelement, TN or EN, is a copper-nickel alloy known ambiguously as constantan. The word constantan refers to a family of copper-nickel alloys containing anywhere from 45 to 60 percent copper. These alloys also typically contain small percentages of cobalt, manganese and iron, as well as trace impurities of other elements such as carbon, magnesium, silicon, etc. The constantan for type T thermocouples usually contains about 55 percent copper, 45 percent nickel, and small but thermoelectrically significant amounts, about 0.1 percent or larger, of cobalt, iron, or manganese. It should be emphasized that type TN (or EN) thermoelements are NOT generally interchangeable with type JN thermoelements although they are all referred to as “constantan”. In order to provide some differentiation in nomenclature, type TN (or EN) is often referred to as Adams’ (or RP1080) constantan and type JN is usually referred to as SAMA constantan.

The thermoelectric relations for type TN and type EN thermoelements are the same, that is the voltage versus temperature equations and tables for platinum versus type TN thermoelements apply to both types of thermoelements over the temperature range recommended for each thermocouple type. However, it should not be assumed that type TN and type EN thermoelements may be used interchangeably or that they have the same commercial initial calibration tolerances.

The low temperature research [8] by members of the NBS Cryogenics Division showed that the type T thermocouple may be used down to liquid helium temperatures (about 4K) but that its Seebeck coefficient becomes quite small below 20K. Its Seebeck coefficient at 20K is only about 5.6 $\mu$ V/K, being roughly two-thirds that of the type E thermocouple. The thermoelectric homogeneity of most type TP and type TN (or EN) thermoelements is reasonably good. There is considerable variability, however, in the thermoelectric properties of type TP thermoelements below about 70K caused by variations in the amounts and types of



impurities present in these nearly pure materials. The high thermal conductivity of the type TP thermoelements can also be troublesome in precise applications. For these reasons, type T thermocouples are generally unsuitable for use below about 20K. Type E thermocouples are recommended as the most suitable of the letter-designated thermocouple types for general low-temperature use, since they offer the best overall combination of desirable properties. Type T thermocouples are recommended by the ASTM [5] for use in the temperature range from -200°C to 370°C in vacuum or in oxidizing, reducing or inert atmospheres. The suggested upper temperature limit for continuous service of protected type T thermocouples is set at 370°C for AWG 14 (1.63 mm) thermoelements since type TP thermoelements oxidize rapidly above this temperature. However, the thermoelectric properties of type TP thermoelements are apparently not grossly affected by oxidation since negligible changes in the thermoelectric voltage were observed at NBS [10] for AWG 12, 18, and 22 type TP thermoelements during 30 hours of heating in air at 500°C. At this temperature the type TN thermoelements have good resistance to oxidation and exhibit only small voltage changes heated in air for long periods of time, as shown by the studies of Dahl [11]. Higher operating temperatures, up to at least 800°C, are possible in inert atmospheres where the deterioration of the type TP thermoelement is no longer a problem. The use of type T thermocouples in hydrogen atmospheres at temperatures above about 370°C is not recommended since type TP thermoelements may become brittle.

Type T thermocouples are not well suited for use in nuclear environments since both thermoelements are subject to significant changes in composition under thermal neutron irradiation. The copper in the thermoelements is converted to nickel and zinc.

Because of the high thermal conductivity of type TP thermoelements, special care should be exercised when using the thermocouples to ensure that the measuring and reference junctions assume the desired temperatures.

ASTM Standard E230-87 in the 1992 Annual Book of ASTM Standards [7] specifies that the initial calibration tolerances for type T commercial thermocouples be  $\pm 1^\circ\text{C}$  or  $\pm 0.75$  percent (whichever is greater) between  $0^\circ\text{C}$  and  $350^\circ\text{C}$ , and  $\pm 1^\circ\text{C}$  or  $\pm 1.5$  percent (whichever is greater) between  $-200^\circ\text{C}$  and  $0^\circ\text{C}$ . Type T thermocouples can also be supplied to meet special tolerances which are equal to approximately one-half the standard tolerances given above. Type T thermocouple materials are normally supplied to meet the tolerances specified for temperatures above  $0^\circ\text{C}$ . However, the same materials may not satisfy the tolerances specified for the  $-200^\circ\text{C}$  to  $0^\circ\text{C}$  range. If materials are required to meet the tolerances below  $0^\circ\text{C}$ , this should be specified when they are purchased.

The suggested upper temperature limit of 370°C given in the ASTM standard [7] for protected type T thermocouples applies to AWG 14 (1.63 mm) wire. It decreases to 260°C for AWG 20 (0.81 mm), 200°C for AWG

24 or 28 (0.51 mm or 0.33 mm), and 150°C for AWG 30 (0.25 mm). These temperature limits apply to thermocouples used in conventional closed-end protecting tubes and they are intended only as a rough guide to the user. They do not apply to thermocouples having compacted mineral oxide insulation.

## References

- [1] Preston-Thomas, H. The International Temperature Scale of 1990 (ITS-90). *Metrologia* 27, 3-10; 1990. *ibid.* p. 107.
- [2] The International Practical Temperature Scale of 1968, Amended Edition of 1975. *Metrologia* 12, 7-17, 1976.
- [3] Mangum, B. W.; Furukawa, G. T. Guidelines for realizing the International Temperature Scale of 1990 (ITS-90). *Natl. Inst. Stand. Technol. Tech. Note 1265*; 1990 August. 190 p.
- [4] The 1976 Provisional 0.5 to 30 K Temperature Scale. *Metrologia* 15, 65-68; 1979.
- [5] ASTM, American Society for Testing and Materials. Manual on the use of thermocouples in temperature measurement. *Special Tech. Publ. 470B*; edited by Benedict, R. P.; Philadelphia: ASTM; 1981. 258p.
- [6] Hansen, M.; Anderko, K. Constitution of binary alloys. New York: McGraw-Hill Book Co.; 1958.
- [7] ASTM, American Society for Testing and Materials, Standard E230-87, *1992 Annual Book of ASTM Standards*. Vol. 14.03; Philadelphia: ASTM; 1992. 102-230.
- [8] Sparks, L. L.; Powell, R. L.; Hall, W. J. Reference tables for low-temperature thermocouples. *Natl. Bur. Stand. (U.S.) Monogr. 124*; 1972 June. 61p.
- [9] Starr, C.D.; Wang, T. P. Effect of oxidation on stability of thermocouples, *Proceedings of the American Society for Testing and Materials* Vol. 63, 1185-1194; 1963.
- [10] Roeser, W. F.; Dahl, A. I. Reference tables for iron-constantan and copper-constantan thermocouples. *J. Res. Natl. Bur. Stand. (U.S.)* 20, 337-355; RP1080; 1938 March.
- [11] Dahl, A. I. Stability of base-metal thermocouples in air from 800 to 2200°F. *J. Res. Natl. Bur. Stand. (U.S.)* 24, 205-224; RP1278; 1940 February.
- [12] Sparks, L. L.; Powell, R. L. Low temperatures thermocouples: KP, “normal” silver, and copper versus Au-0.02 at % Fe and Au-0.07 at % Fe. *J. Res. Natl. Bur. Stand. (U.S.)* 76A(3), 263-283; 1972 May-June.
- [13] Burley, N. A.; Hess, R. M.; Howie, C. F.; Coleman, J. A. The nicrosil versus nisil thermocouple: A critical comparison with the ANSI standard

- letter-designated base-metal thermocouples. *Temperature: Its Measurement and Control in Science and Industry*; Vol. 5, Schooley, J. F., ed.; New York: American Institute of Physics; 1982. 1159-1166.
- [14] Potts, J. F. Jr.; McElroy, D. L. The effects of cold working, heat treatment, and oxidation on the thermal emf of nickel-base thermoelements. Herzfeld, C. M.; Brickwedde, F. G.; Dahl, A. I.; Hardy, J. D., ed. *Temperature: Its Measurement and Control in Science and Industry*; Vol. 3, Part 2; New York: Reinhold Publishing Corp.; 1962. 243-264.
- [15] Burley, N. A.; Ackland, R. G. The stability of the thermo-emf/temperature characteristics of nickel-base thermocouples. *Jour. of Australian Inst. of Metals* 12(1), 23-31; 1967.
- [16] Burley, N. A. Nicrosil and nisil: Highly stable nickel-base alloys for thermocouples. *Temperature: Its Measurement and Control in Science and Industry*; Vol. 4, Plumb, H. H., ed.; Pittsburgh: Instrument Society of America; 1972. 1677-1695.
- [17] Wang, T. P.; Starr, C. D. Electromotive force stability of nicrosil-nisil. *Journal of Testing and Evaluation* 8(4), 192-198; 1980.
- [18] Starr, C. D.; Wang, T. P. Effect of oxidation on stability of thermocouples, *Proceedings of the American Society for Testing and Materials* Vol. 63 1185-1194; 1963.
- [19] Bentley, R. E. Short-term instabilities in thermocouples containing nickel-based alloys. *High Temperatures- High Pressures* 15, 599-611; 1983.
- [20] Kollie, T. G.; Horton, J. L.; Carr, K. R.; Herskovitz, M. B.; Mossman, C. A. Temperature measurement errors with type K (Chromel vs. Alumel) thermocouples due to short-ranged ordering in Chromel. *Rev. Sci. Instrum.* 46, 1447-1461; 1975.
- [21] ASTM, American Society for Testing and Materials, Standard E1159-87, *1992 Annual Book of ASTM Standards*. Vol. 14.03; Philadelphia: ASTM; 1992. 388-389.
- [22] Bedford, R. E.; Ma, C. K.; Barber, C. R.; Chandler, T. R.; Quinn, T. J.; Burns, G. W.; Scroger, M. New reference tables for platinum 10% rhodium/platinum and platinum 13% rhodium/platinum thermocouples. *Temperature: Its Measurement and Control in Science and Industry*; Vol. 4, Part 3, p. 1585; Plumb, H. H., ed.; Pittsburgh: Instrument Society of America; 1972.
- [23] Burns, G. W.; Strouse, G. F.; Mangum, B. W.; Croarkin, M. C.; Guthrie, W. F.; Chattle, M. New reference functions for platinum-13% rhodium versus platinum (type R) and platinum-30% rhodium versus platinum-6% rhodium (type B) thermocouples based on the ITS-90. in *Temperature: Its Measurement and Control in Science and*

- Industry*; Vol. 6; Schooley, J. F., ed.; New York: American Institute of Physics; 1992. 559-564.
- [24] Glawe, G. E.; Szaniszlo, A. J. Long-term drift of some noble- and refractory-metal thermocouples at 1600K in air, argon, and vacuum. *Temperature: Its Measurement and Control in Science and Industry*; Vol. 4; Plumb, H. H., ed.; Pittsburgh: Instrument Society of America; 1972. 1645-1662.
- [25] Walker, B. E.; Ewing, C. T.; Miller, R. R. Thermoelectric instability of some noble metal thermocouples at high temperatures. *Rev. Sci. Instrum.* 33, 1029-1040; 1962.
- [26] Walker, B. E.; Ewing, C. T.; Miller, R. R. Study of the instability of noble metal thermocouples in vacuum. *Rev. Sci. Instrum.* 36, 601-606; 1965.
- [27] Bedford, R. E.; Ma, C. K.; Barber, C. R.; Chandler, T. R.; Quinn, T. J.; Burns, G. W.; Scroger, M. New reference tables for platinum 10% rhodium/platinum and platinum 13% rhodium/platinum thermocouples. *Temperature: Its Measurement and Control in Science and Industry*; Vol. 4; Plumb, H. H., ed.; Pittsburgh: Instrument Society of America; 1972. 1585-1603.
- [28] Burns, G. W.; Strouse, G. F.; Mangum, B. W.; Croarkin, M. C.; Guthrie, W. F.; Marcarino, P.; Battuello, M.; Lee, H. K.; Kim, J. C.; Gam, K. S.; Rhee, C.; Chattle, M.; Arai, M.; Sakurai, H.; Pokhodun, A. I.; Moiseeva, N. P.; Perevalova, S. A.; de Groot, M. J.; Zhang, J.; Fan, K.; Wu, S. New reference functions for platinum-10% rhodium versus platinum (type S) thermocouples based on the ITS-90, Part I and Part II. in *Temperature: Its Measurement and Control in Science and Industry*; Vol. 6; Schooley, J. F., ed.; New York: American Institute of Physics; 1992. 537-546.
- [29] Bentley, R. E. Changes in Seebeck coefficient of Pt and Pt 10% Rh after use to 1700C in high-purity polycrystalline alumina. *Int. J. Thermophys.* 6(1), 83-99; 1985.
- [30] McLaren, E. H.; Murdock, E. G. New considerations on the preparation, properties and limitations of the standard thermocouple for thermometry. *Temperature: Its Measurement and Control in Science and Industry*; Vol. 4; Plumb, H. H., ed.; Pittsburgh: Instrument Society of America; 1972. 1543-1560.
- [31] McLaren, E. H.; Murdock, E. G. The properties of Pt/PtRh thermocouples for thermometry in the range 0-1100°C: I. Basic measurements with standard thermocouples. *National Research Council of Canada Publication APH 2212/NRCC 17407*; 1979.
- [32] McLaren, E. H.; Murdock, E. G. The properties of Pt/PtRh thermocouples for thermometry in the range 0-1100°C: II. Effect of

- heat treatment on standard thermocouples. *National Research Council of Canada Publication APH 2213/NRCC 17408*; 1979.
- [33] McLaren, E. H.; Murdock, E. G. Properties of some noble and base metal thermocouples at fixed points in the range 0-1100°C. *Temperature: Its Measurement and Control in Science and Industry*; Vol. 5; Schooley, J. F., ed.; New York: American Institute of Physics; 1982. 953-975.
- [34] Bentley, R. E.; Jones, T. P. Inhomogeneities in type S thermocouples when used to 1064°C. *High Temperatures- High Pressures* 12, 33-45; 1980.
- [35] Rhys, D. W.; Taimsalu, P. Effect of alloying additions on the thermoelectric properties of platinum. *Engelhard Tech. Bull.* 10, 41-47; 1969.
- [36] Cochrane, J. Relationship of chemical composition to the electrical properties of platinum. *Engelhard Tech. Bull.* 11, 58-71; 1969. Also in *Temperature: Its Measurement and Control in Science and Industry*; Vol. 4; Plumb, H. H., ed.; Pittsburgh: Instrument Society of America; 1972. 1619-1632.
- [37] Aliotta, J. Effects of impurities on the thermoelectric properties of platinum. *Inst. and Control Systems*, 106-107; March 1972.
- [38] Burns, G. W.; Gallagher, J. S. Reference tables for the Pt-30 percent Rh versus Pt-6 percent Rh thermocouple. *J. Res. Natl. Bur. Stand. (U.S.)* 70C, 89-125; 1966.
- [39] Ehringer, H. Uber die lebensdauer von PtRh-thermoelementen. *Metall* 8, 596-598; 1954.
- [40] Acken, J. S. Some properties of platinum-rhodium alloys. *J. Res. Natl. Bur. Stand. (U.S.)* 12, 249; RP650; 1934.
- [41] Hendricks, J. W.; McElroy, D. L. High temperature- high vacuum thermocouple drift tests. *Environmental Quarterly*, 34-38; March 1967.
- [42] Zysk, E. D. Platinum metal thermocouples. *Temperature: Its Measurement and Control in Science and Industry*; Vol. 3; Herzfeld, C. M., ed.; New York: Reinhold Publishing Corp.; 1962. Part 2, pp. 135-156.
- [43] Starr, C. D.; Wang, T. P. A new stable nickel-base thermocouple. *Journal of Testing and Evaluation* 4(1), 42-56; 1976.
- [44] Burley, N. A.; Powell, R. L.; Burns, G. W.; Scroger, M. G. The nicrosil versus nilsil thermocouple: properties and thermoelectric

- reference data. *Natl. Bur. Stand. (U.S.) Monogr. 161*; 1978 April. 167p.
- [45] Burley, N. A.; Jones, T. P. Practical performance of nicrosil-nisil thermocouples. *Temperature Measurement, 1975*; Billing, B. F.; Quinn, T. J., ed.; London and Bristol: Institute of Physics; 1975. 172-180.
- [46] Burley, N. A.; Hess, R. M.; Howie, C. F. Nicrosil and nisil: new nickel-based thermocouple alloys of ultra-high thermoelectric stability. *High Temperatures- High Pressures* 12, 403-410; 1980.
- [47] Burley, N. A.; Cocking, J. L.; Burns, G. W.; Scroger, M. G. The nicrosil versus nisil thermocouple: the influence of magnesium on the thermoelectric stability and oxidation resistance of the alloys. *Temperature: Its Measurement and Control in Science and Industry*; Vol. 5, Schooley, J. F., ed.; New York: American Institute of Physics; 1982. 1129-1145.
- [48] Wang, T. P.; Starr, C. D. Nicrosil-nisil thermocouples in production furnaces in the 538°C (1000°F) to 1177°C (2150°F) range. *ISA Transactions* 18(4), 83-99; 1979.
- [49] Wang, T. P.; Starr, C. D. Oxidation resistance and stability of nicrosil-nisil in air and in reducing atmospheres. *Temperature: Its Measurement and Control in Science and Industry*; Vol. 5, Schooley, J. F., ed.; New York: American Institute of Physics; 1982. 1147-1157.
- [50] Hess, T. G. Nicrosil-nisil: high-performance thermocouple alloys. *ISA Transactions* 16(3), 81-84; 1977.
- [51] Anderson, R. L.; Lyons, J. D.; Kollie, T. G.; Christie, W. H.; Eby, R. Decalibration of sheathed thermocouples. *Temperature: Its Measurement and Control in Science and Industry*; Vol. 5., Schooley, J. F., ed.; New York: American Institute of Physics; 1982. 977-1007.
- [52] Bentley, R. E.; Morgan, T. L. Ni-based thermocouples in the mineral-insulated metal-sheathed format: thermoelectric instabilities to 1100°C. *J. Phys. E: Sci. Instrum.* 19, 262-268; 1986.
- [53] Wang, T. P.; Bediones, D. 10,000 hr. stability test of types K, N, and a Ni-Mo/Ni-Co thermocouple in air and short-term tests in reducing atmospheres. *Temperature: Its Measurement and Control in Science*

- and Industry*; Vol. 6; Schooley, J. F., ed.; New York: American Institute of Physics; 1992. 595-600.
- [54] Burley, N. A. N-CLAD-N: A novel advanced type N integrally-sheathed thermocouple of ultra-high thermoelectric stability. *High Temperatures- High Pressures* 8, 609-616; 1986.
- [55] Burley, N. A. A novel advanced type N integrally-sheathed thermocouple of ultra-high thermoelectric stability. *Thermal and Temperature Measurement in Science and Industry*; 3rd Int. IMEKO Conf.; Sheffield; Sept. 1987. 115-125.
- [56] Burley, N. A. "N-CLAD-N" A novel integrally sheathed thermocouple: optimum design rationale for ultra-high thermoelectric stability. *Temperature: Its Measurement and Control in Science and Industry*; Vol. 6; Schooley, J. F., ed.; New York: American Institute of Physics; 1992. 579-584.
- [57] Bentley, R. E. The new nicrosil-sheathed type N MIMS thermocouple: an assessment of the first production batch. *Mater. Australas.* 18(6), 16-18; 1986.
- [58] Bentley, R. E.; Russell, Nicrosil sheathed mineral-insulated type N thermocouple probes for short-term variable-immersion applications to 1100°C. *Sensors and Actuators* 16, 89-100; 1989.
- [59] Bentley, R. E. Irreversible thermoelectric changes in type K and type N thermocouple alloys within nicrosil-sheathed MIMS cable. *J. Phys. D.* 22, 1908-1915; 1989.
- [60] Bentley, R. E. Thermoelectric behavior of Ni-based ID-MIMS thermocouples using the nicrosil-plus sheathing alloy. *Temperature: Its Measurement and Control in Science and Industry*; Vol. 6; Schooley, J. F., ed.; New York: American Institute of Physics; 1992. 585-590.
- [61] Bentley, R. E. Thermoelectric hysteresis in nicrosil and nisil. *J. Phys. E: Sci. Instrum.* 20, 1368-1373; 1987.
- [62] Bentley, R. E. Thermoelectric hysteresis in nickel-based thermocouple alloys. *J. Phys. D.* 22, 1902-1907; 1989. Publication 1769-UM004A-EN-P







# Appendix D

## Using Thermocouple Junctions

This appendix describes the types of thermocouple junctions available, and explains the trade-offs in using them with the 1769-IF8u thermocouple/mV analog input module.



**ATTENTION** Take care when choosing a thermocouple

junction, and connecting it from the environment to the module. If you do not take adequate precautions for a given thermocouple type, the electrical isolation of the module might be compromised.

Available thermocouple junctions are:

- grounded
- ungrounded (isolated)
- exposed

### Using a Grounded Junction Thermocouple

With a grounded junction thermocouple, the measuring junction is physically connected to the protective sheath, forming a completely sealed integral junction. If the sheath is metal (or electrically conductive), there is electrical continuity between the junction and sheath. The junction is protected from corrosive or erosive conditions. The response time approaches that of the exposed junction type described in Using an Exposed Junction Thermocouple.

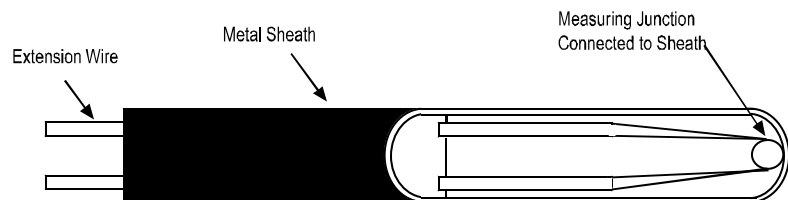

The shield input terminals for a grounded junction thermocouple are connected together and then connected to chassis ground. Use of this thermocouple with an electrically conductive sheath removes the thermocouple signal to chassis ground isolation of the module. In addition, if multiple grounded junction thermocouples are used, the module channel-to-channel isolation is removed, since there is no isolation between signal

and sheath (sheaths are tied together). It should be noted that the isolation is removed even if the sheaths are connected to chassis ground at a location other than the module, since the module is connected to chassis ground.

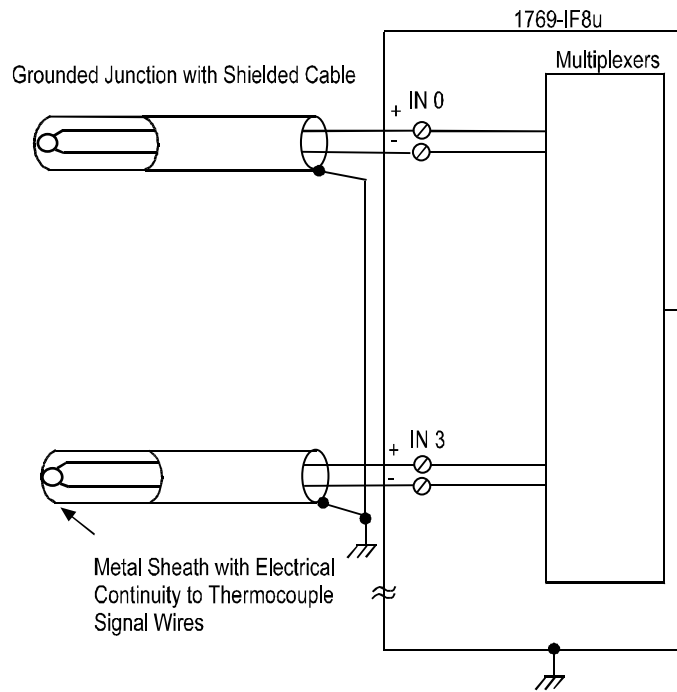

Spectrum Controls recommends that a grounded junction thermocouple have a protective sheath made of electrically insulated material (for

example, ceramic). An alternative is to float the metal sheath with respect to any path to chassis ground or to another thermocouple metal sheath. Thus, the metal sheath must be insulated from electrically conductive process material, and have all connections to chassis ground broken. Note that a floated sheath can result in a less noise-immune thermocouple signal.

### Using an Ungrounded (Isolated) Junction Thermocouple

An ungrounded (isolated) junction thermocouple uses a measuring junction that is electrically isolated from the protective metal sheath. This junction type is often used in situations when noise will affect readings, as well as situations using frequent or rapid temperature cycling. For this type of thermocouple junction, the response time is longer than for the grounded junction.

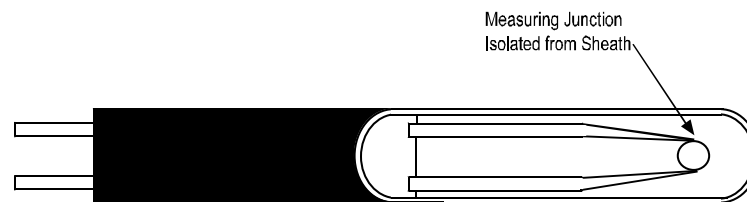

### Using an Exposed Junction Thermocouple

An exposed junction thermocouple uses a measuring junction that does not have a protective metal sheath. A thermocouple with this junction type provides the fastest response time but leaves thermocouple wires unprotected against corrosive or mechanical damage.

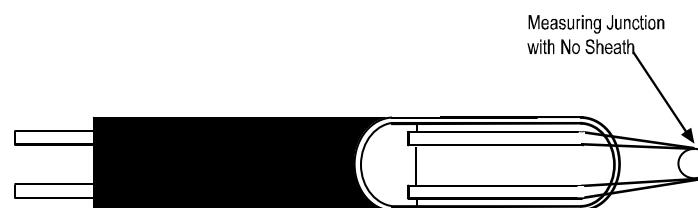

As shown in the next illustration, using an exposed junction thermocouple can result in removal of channel-to-channel isolation. Isolation is removed if multiple exposed thermocouples are in direct contact with electrically conductive process material.

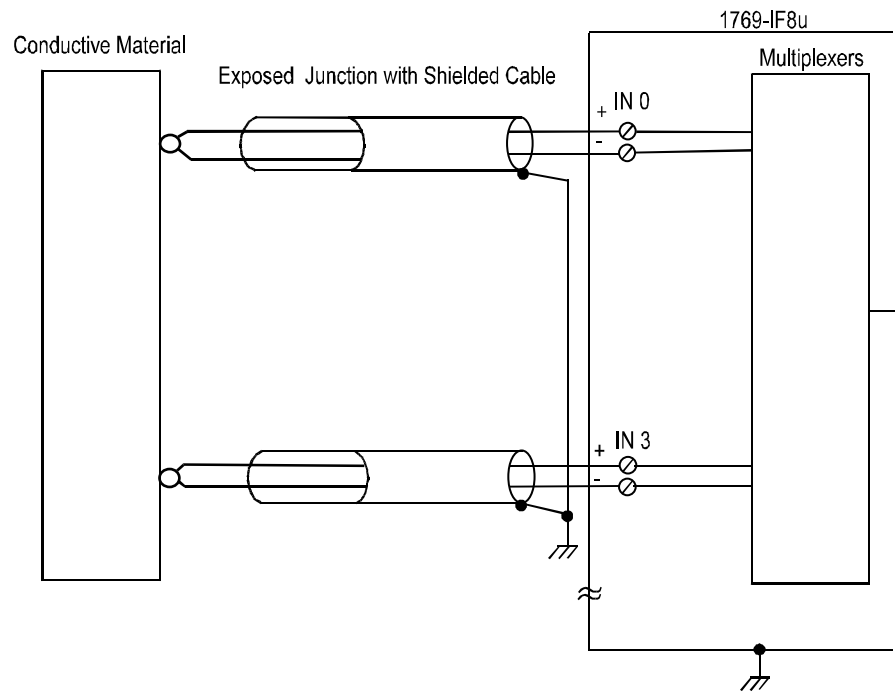

To prevent violation of channel-to-channel isolation:

- For multiple exposed junction thermocouples, do not allow the measuring junctions to make direct contact with electrically conductive process material.
- Preferably use a single exposed junction thermocouple with multiple ungrounded junction thermocouples.
- Consider using all ungrounded junction thermocouples instead of the exposed junction type.







For example, to obtain the general status of channel 2 of the module located in slot e, use address I:e.6/2.

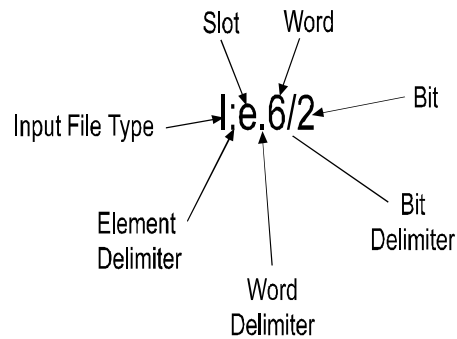

**NOTE** The end cap does not use a slot address.

### 1769sc-IF8U Configuration File

The configuration file contains information you use to define the way a specific channel functions. The configuration file is explained in more detail in *Configuring Channels* in chapter 4.

The configuration file is modified using the programming software configuration screen. For an example of module configuration using RSLogix 500, see *Configuring the 1769sc-IF8U in a MicroLogix 1500 System*.

| Parameter              | Default Setting      |
|------------------------|----------------------|
| Disable/Enable Channel | Enabled              |
| Filter Frequency       | 60 Hz                |
| Open Circuit           | Upscale              |
| Input Range            | 4 to 20 mA           |
| Data Format            | Engineering Units X1 |
| Cyclic Lead Comp.      | Enabled              |
| 4 Wire RTD             | Disabled             |



## Configuring the 1769sc-IF8U in a MicroLogix 1500 System

This example takes you through configuring your 1769scIF8U universal analog input module with RSLogix 500 programming software, assumes your module is installed as expansion I/O in a MicroLogix 1500 system, and that RSLinx™ is properly configured and a communications link has been established between the MicroLogix processor and RSLogix 500.

Start RSLogix and create a MicroLogix 1500 application. The following screen appears:

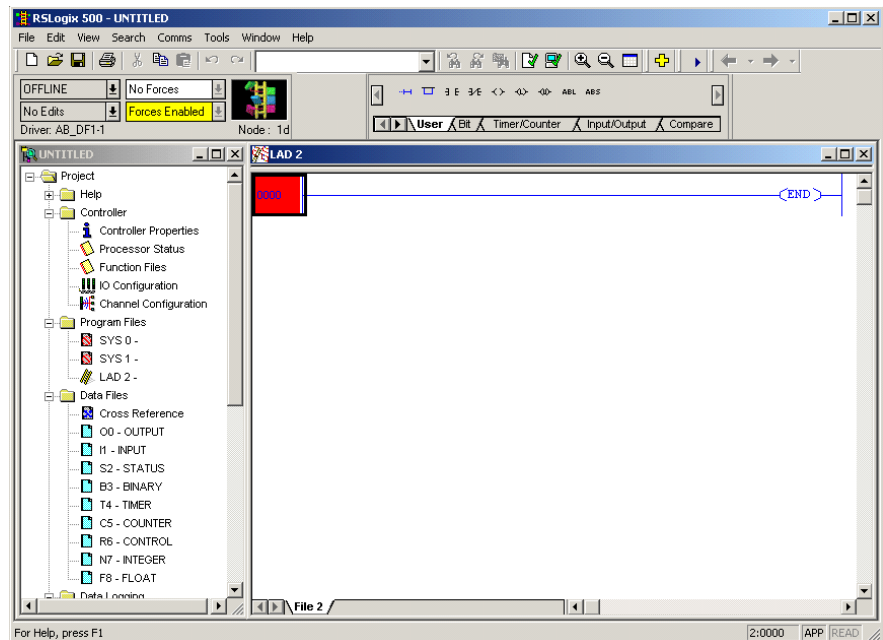

While offline, double-click on the IO Configuration icon under the controller folder and the following IO Configuration screen appears.

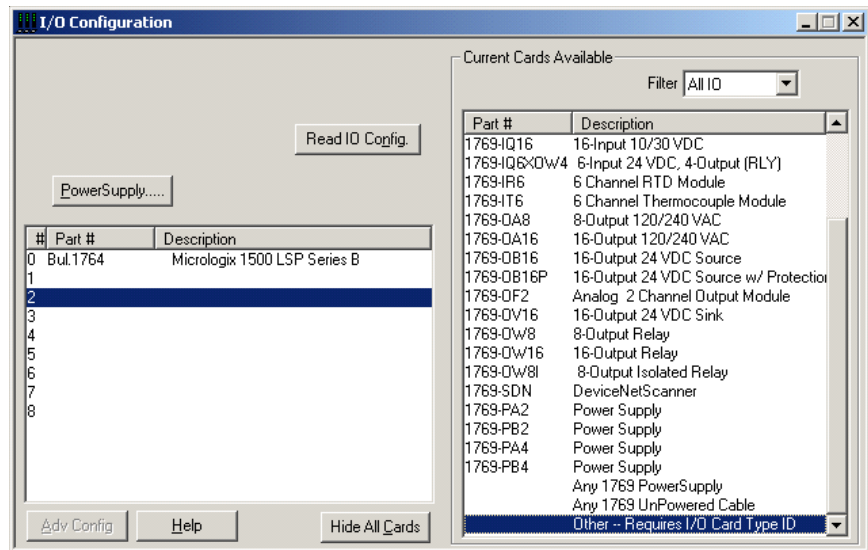

This screen allows you to manually enter expansion modules into expansion slots, or to automatically read the configuration of the controller. To read the existing controller configuration, click on the Read IO Config button.

A communications dialog appears, identifying the current communications configuration so that you can verify the target controller. If the communication settings are correct, click on Read IO Config.

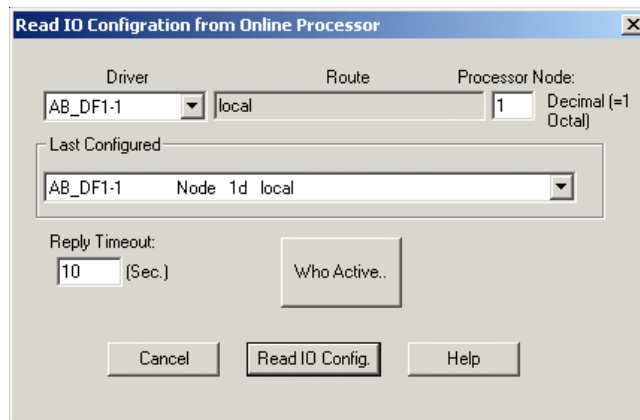

The actual I/O configuration is displayed. In this example, a second tier of

I/O is attached to the MicroLogix 1500 processor.

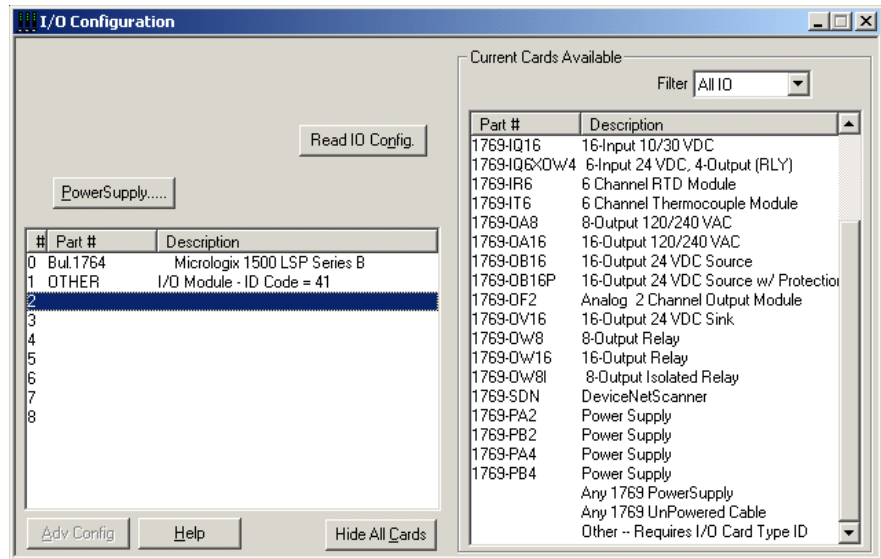

The 1769sc-IF8U module is installed in slot 1. To configure the module, double-click on the module/slot. The general configuration screen appears.

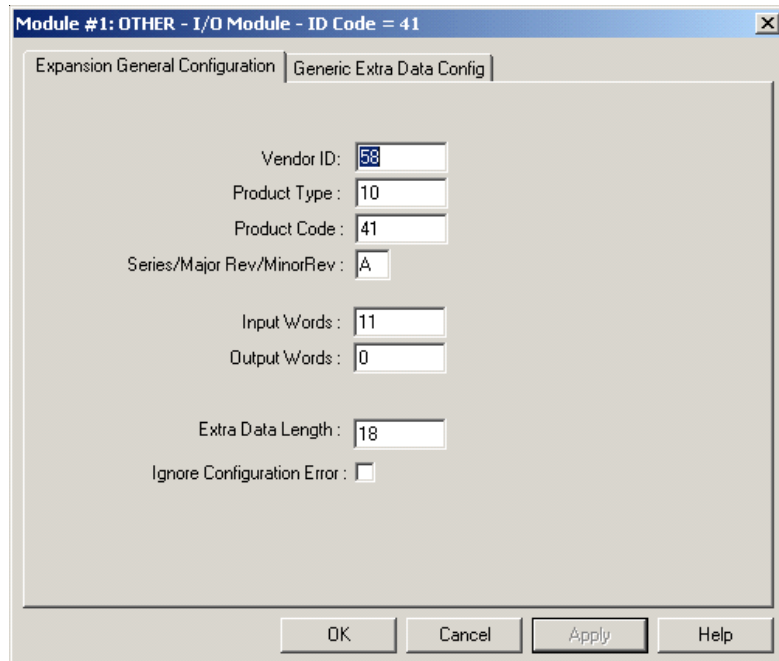



When using the read IO configuration feature in RSLogix, you need to manually enter 18 into the “extra data length” field.

To configure the module select the *Generic Extra Data Configuration* tab. Enter the decimal equivalent of each configuration word. There are a total of 18 words that need to be configured altogether. The module default settings are used if all the configuration words are left at zero..

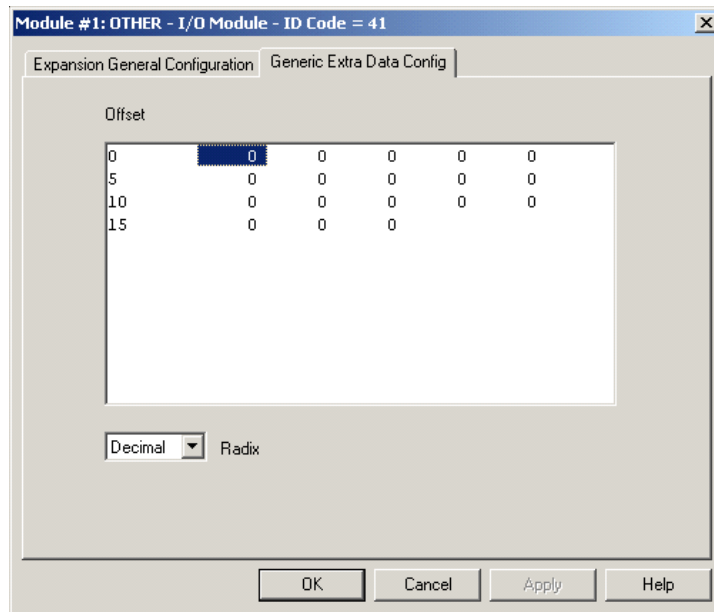

**NOTE** For a complete description of each of these parameters and the choices available for each of them, refer to chapter 4.

**NOTE:** Words 10 through 17 are reserved and must contain zero.

# Appendix F

## Configuring Your 1769sc-IF8U Module for CompactLogix Controllers in RSLogix 5000

The 1769sc-IF8U module can be configured in RSLogix 5000 using either the AOP (Add On Profile) or the generic module profile depending on the level of firmware installed on the PLC. The AOP can be used on controllers running firmware version 15 or higher. The generic profile must be used on controllers running firmware level 14 or older. The AOP can be found on the Spectrum Controls website at

<http://www.spectrumcontrols.com/downloads.htm>.

The following procedure describes how to configure the 1769sc-IF8U in Rslogix 5000 using the generic module profile.

To configure a 1769sc-IF8U Universal module for a CompactLogix Controller using RSLogix 5000 with the 1769 Generic Profile, begin a new project in RSLogix 5000. Click on the new project icon or on the FILE pull-down menu and select NEW. The following screen appears:

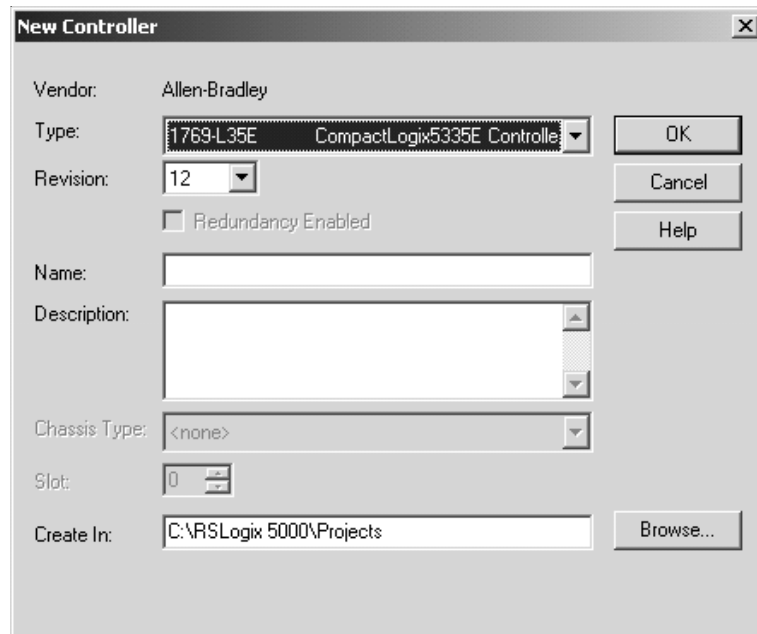

Choose your controller type and enter a name for your project, then click OK. The following main RSLogix 5000 screen appears:

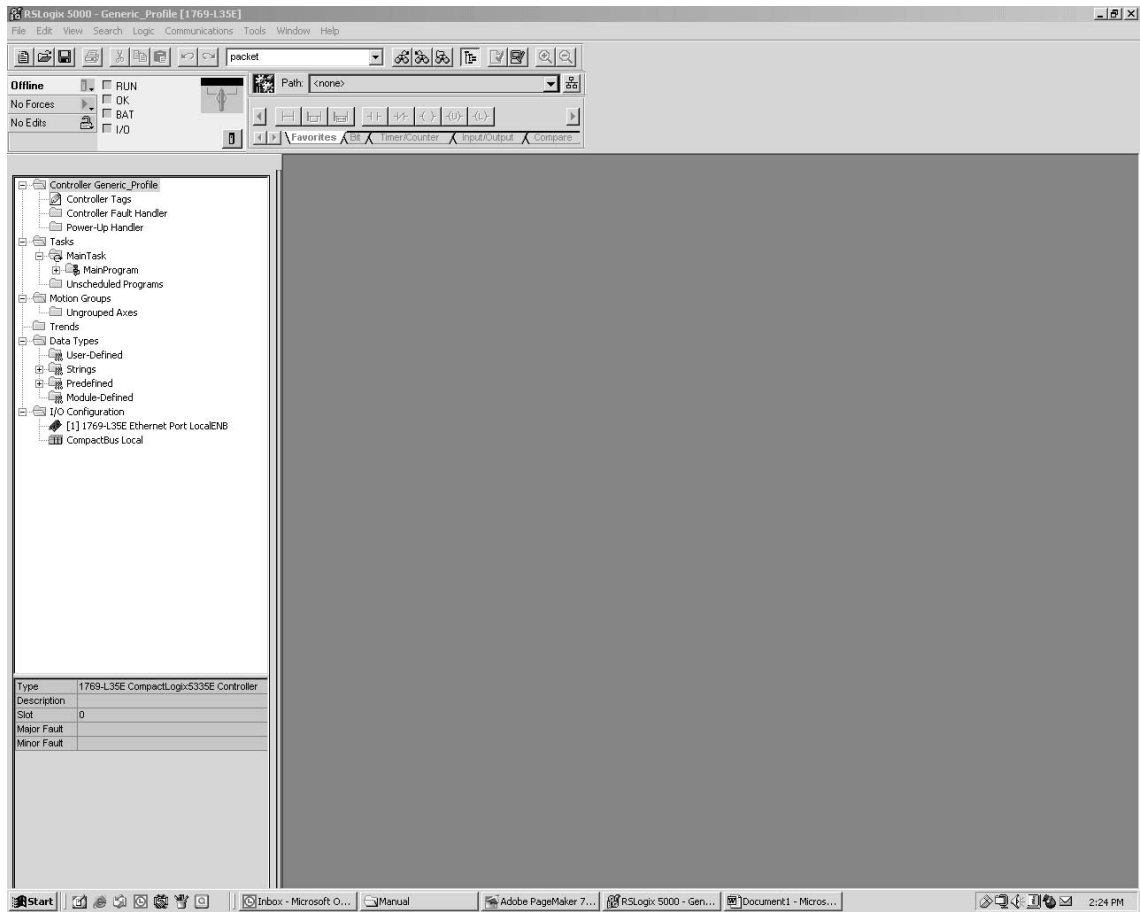

In the Controller Organizer on the left of the screen, right click on “[0] CompactBus Local”, select New Module, and the following screen appears:

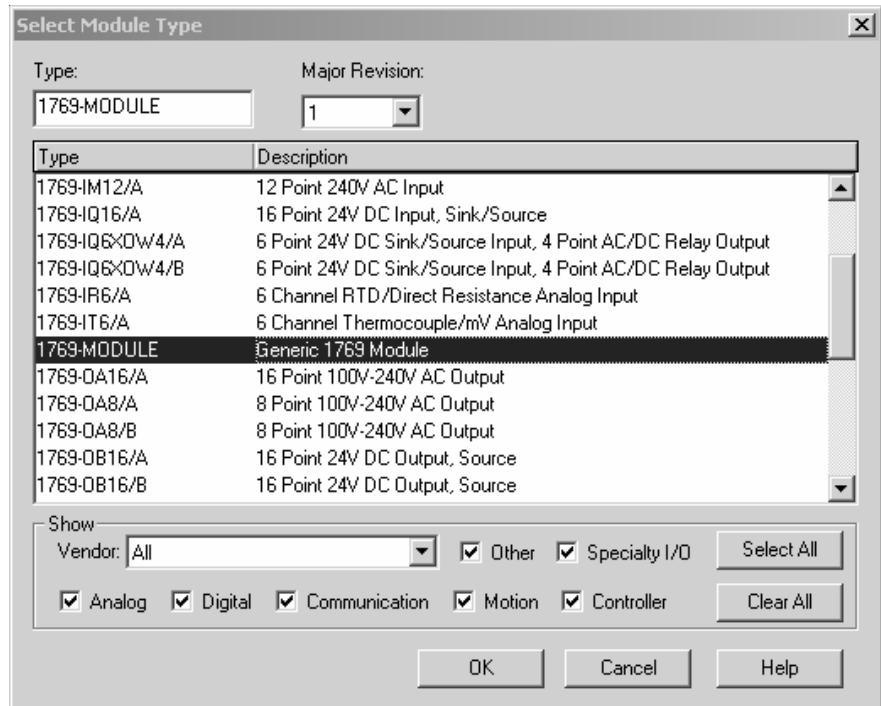

This screen is used to narrow your search for I/O modules to configure into your system. With the initial release of the CompactLogix5320 controller, this screen only includes the “Generic 1769 Module”. Click the OK button and the following default Generic Profile screen appears:

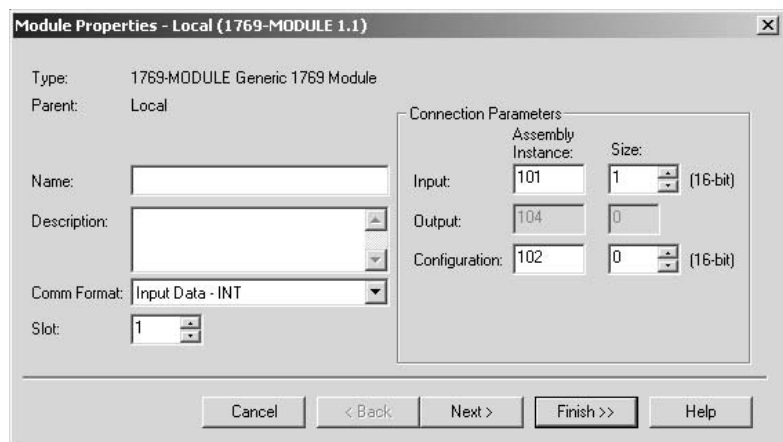

First, select the Comm Format (“Input Data – INT” for the 1769sc-IF8U), then fill in the name field. For this example, “IF8U” is used to help identify

the module type in the Controller Organizer. The Description field is optional and may be used to provide more details concerning this I/O module in your application.

The slot number must be selected next, although it will begin with the first available slot number, 1, and increments automatically for each subsequent Generic Profile you configure. For this example, the 1769sc-IF8U Universal module is located in slot 1.

The Comm Format, Assembly Instance and Size values are listed in the following table for the 1769sc-IF8U Universal module:

| 1769 I/O Module | Comm Format      | Parameter | Assembly Instance | Size (16-bit) |
|-----------------|------------------|-----------|-------------------|---------------|
| IF8U            | Input Data - INT | Input     | 101               | 11            |
|                 |                  | Output    | 104               | 0             |
|                 |                  | Config    | 102               | 18            |

Enter the Assembly Instance numbers and their associated sizes for the 1769sc-IF8U module into the Generic Profile. When complete, the Generic Profile for a 1769sc-IF8U module should look like the following:

The screenshot shows the 'Module Properties' dialog box for a 1769-IF8U module. The main dialog has the following fields: Type: 1769-MODULE Generic 1769 Module, Parent: Local, Name: IF8U, Description: (empty), Comm Format: Input Data - INT, Slot: 1. A 'Connection Parameters' sub-dialog is open, showing the following values: Input: Assembly Instance 101, Size 11 (16-bit); Output: Assembly Instance 104, Size 0; Configuration: Assembly Instance 102, Size 18 (16-bit). The 'Finish >>' button is highlighted.

At this point you may click “Finish” to complete the configuration of your I/O module.

Configure each I/O module in this manner. The CompactLogix5320 controller supports a maximum of 8 I/O modules. The valid slot numbers to select when configuring I/O modules are 1 through 8.



## Configuring I/O Modules

Once you have created a Generic Profile for 1769sc-IF8U Universal module, you must enter configuration information into the Tag database that is automatically created from the Generic Profile information you entered. This configuration information is downloaded to each module at program download, at power up, and when an inhibited module is uninhibited.

First, enter the Controller Tag database by double-clicking on Controller Tags in the upper portion of the Controller Organizer.

Based on the Generic Profile created earlier for 1769sc-IF8U module, the Controller Tags screen looks like the following:

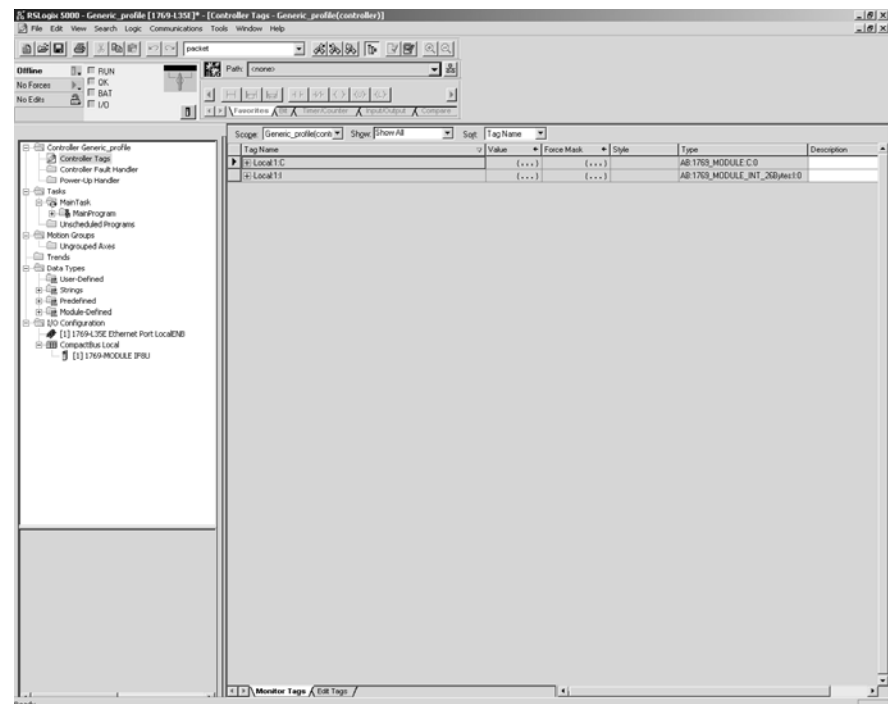

Tag addresses are automatically created for configured I/O modules. All local I/O addresses are preceded by the word Local. These addresses have the following format:

- Input Data: Local:s:I

Configuration Data: Local:s:C

Where *s* is the slot number assigned to the I/O modules in the Generic Profile.

In order to configure an I/O module, you must open up the configuration tag for that module by clicking on the plus sign to the left of the configuration tag in the Controller Tag data base.

|                        |                       |       |         |                    |
|------------------------|-----------------------|-------|---------|--------------------|
| [-] Local:1:C          | {...}                 | {...} |         | AB:1769_MODULE:C:0 |
| [-] Local:1:C.Reserved | 1                     |       | Decimal | DINT               |
| [-] Local:1:C.Data     | {...}                 | {...} | Binary  | INT[198]           |
| [-] Local:1:C.Data[0]  | 2#0000_0000_0000_0000 |       | Binary  | INT                |
| [-] Local:1:C.Data[1]  | 2#0000_0000_0000_0000 |       | Binary  | INT                |
| [-] Local:1:C.Data[2]  | 2#0000_0000_0000_0000 |       | Binary  | INT                |
| [-] Local:1:C.Data[3]  | 2#0000_0000_0000_0000 |       | Binary  | INT                |
| [-] Local:1:C.Data[4]  | 2#0000_0000_0000_0000 |       | Binary  | INT                |
| [-] Local:1:C.Data[5]  | 2#0000_0000_0000_0000 |       | Binary  | INT                |
| [-] Local:1:C.Data[6]  | 2#0000_0000_0000_0000 |       | Binary  | INT                |
| [-] Local:1:C.Data[7]  | 2#0000_0000_0000_0000 |       | Binary  | INT                |
| [-] Local:1:C.Data[8]  | 2#0000_0000_0000_0000 |       | Binary  | INT                |
| [-] Local:1:C.Data[9]  | 2#0000_0000_0000_0000 |       | Binary  | INT                |
| [-] Local:1:C.Data[10] | 2#0000_0000_0000_0000 |       | Binary  | INT                |
| [-] Local:1:C.Data[11] | 2#0000_0000_0000_0000 |       | Binary  | INT                |
| [-] Local:1:C.Data[12] | 2#0000_0000_0000_0000 |       | Binary  | INT                |
| [-] Local:1:C.Data[13] | 2#0000_0000_0000_0000 |       | Binary  | INT                |
| [-] Local:1:C.Data[14] | 2#0000_0000_0000_0000 |       | Binary  | INT                |
| [-] Local:1:C.Data[15] | 2#0000_0000_0000_0000 |       | Binary  | INT                |
| [-] Local:1:C.Data[16] | 2#0000_0000_0000_0000 |       | Binary  | INT                |
| [-] Local:1:C.Data[17] | 2#0000_0000_0000_0000 |       | Binary  | INT                |

## Configuring a 1769sc-IF8U Universal Module

To configure the 1769sc-IF8U module in slot 1, click on the plus sign left of Local:1:C. Configuration data is entered under the Local:1:C.Data tag. Click the plus sign to the left of Local:1:C.Data to reveal the 10 integer data words where configuration data may be entered for the 1769sc-IF8U module. The tag addresses for these 18 words are Local:1:C.Data[0] through Local:1:C.Data[17].

The first two configuration words are used to configure module functions like CJC enable, cyclic calibration, open circuit detection and temperature units (i.e. Celcius, Fahrenheit). Words 2 through 9 are used to configure channels 0 through 7 respectively. All 8 words configure the same parameters for the 8 different channels. For a complete description of each of these parameters and the choices available for each of them, see Configuration Data File in chapter 4.

Once you have entered your configuration selections for each channel, enter your program logic, save your project, and download it to your CompactLogix Controller. Your module configuration data is downloaded to your I/O modules at this time. Your 1769sc-IF8U module input data is located in the following tag addresses when the controller is in Run mode.

| <b>1769sc-IF8U Channel</b> | <b>Tag Address</b> |
|----------------------------|--------------------|
| 0                          | Local:1:I.Data[0]  |
| 1                          | Local:1:I.Data[1]  |
| 2                          | Local:1:I.Data[2]  |
| 3                          | Local:1:I.Data[3]  |
| 4                          | Local:1:I.Data[4]  |
| 5                          | Local:1:I.Data[5]  |
| 6                          | Local:1:I.Data[6]  |
| 7                          | Local:1:I.Data[7]  |

w here 1 represents the slot number of the 1769sc-IF8U module



## Getting Technical Assistance

Note that your module contains electronic components which are susceptible to damage from electrostatic discharge (ESD). An electrostatic charge can accumulate on the surface of ordinary plastic wrapping or cushioning material. **In the unlikely event that the module should need to be returned to Spectrum Controls, please ensure that the unit is enclosed in approved ESD packaging (such as static-shielding / metallized bag or black conductive container).** Spectrum Controls reserves the right to void the warranty on any unit that is improperly packaged for shipment.

For further information or assistance, please contact your local distributor, or call the Spectrum Controls technical Support at :

**USA - 425-746-9481**

## Declaration of Conformity

Available upon request



©2003, Spectrum Controls, Inc. All rights reserved. Specifications subject to change without notice. The Encompass logo and ControlLogix are trademarks of Rockwell Automation.  
Publication 0300198-03 Rev. B July 2012. Printed in U.S.A.

**Corporate Headquarters**

Spectrum Controls Inc.  
P.O. Box 6489  
Bellevue, WA 98008 USA  
Fax: 425-641-9473  
Tel: 425-746-9481

Web Site: [www.spectrumcontrols.com](http://www.spectrumcontrols.com)  
E-mail: [spectrum@spectrumcontrols.com](mailto:spectrum@spectrumcontrols.com)

